

**SERVICE MANUAL
HY 400 &
HP 500
DIRECT DRIVE
TRANSMISSIONS**

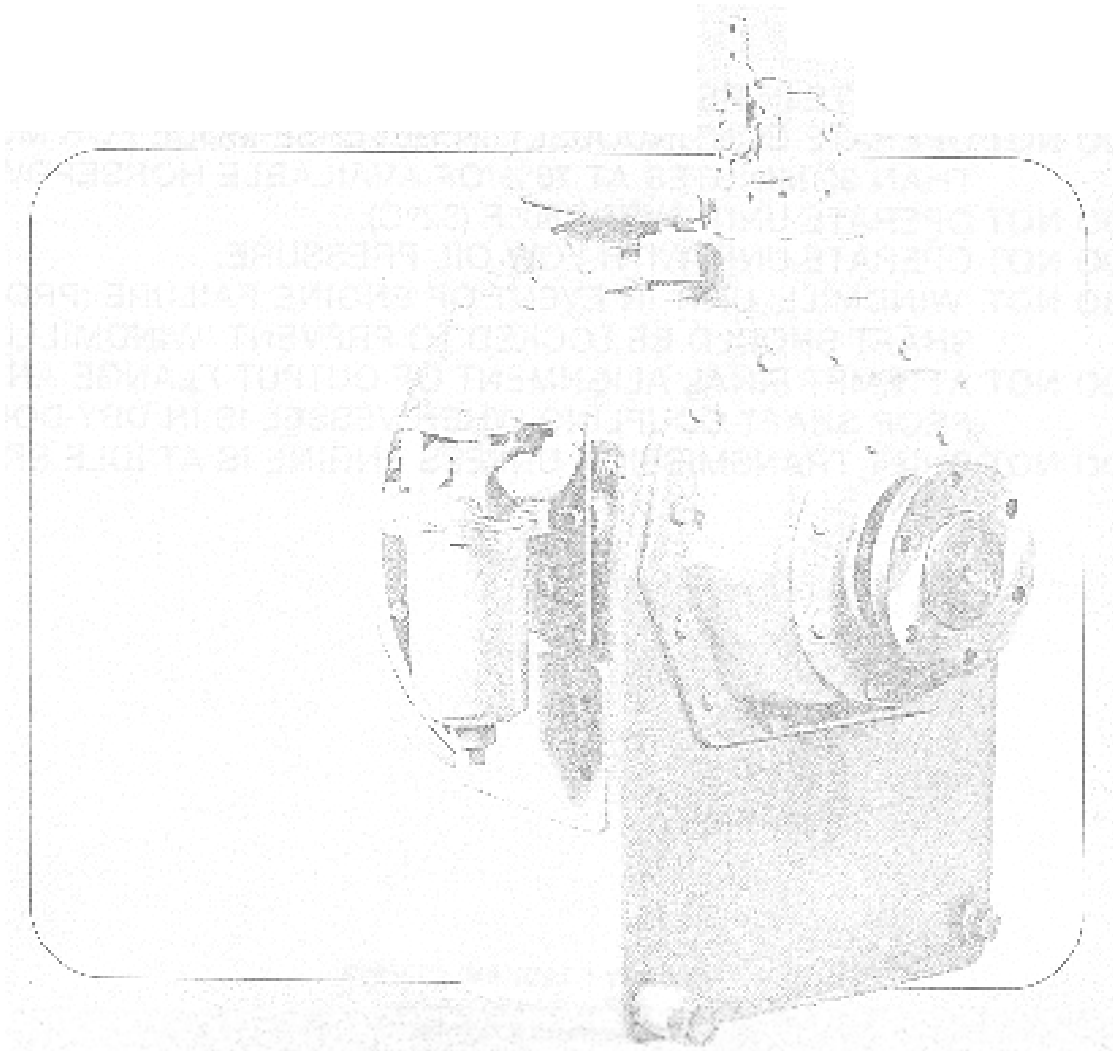

CAPITOL GEARS, INC.

NOTE

THIS SERVICE MANUAL IS
GUARANTEED EFFECTIVE
FOR SERIAL NO.
ONLY.

CAUTION

- DO NOT** OPERATE IN REVERSE MODE TO MOVE VESSEL FORWARD.
- DO NOT** OPERATE CONTINUOUSLY IN REVERSE MODE FOR MORE THAN 30 MINUTES AT 75% OF AVAILABLE HORSEPOWER.
- DO NOT** OPERATE UNIT OVER 180°F (82°C).
- DO NOT** OPERATE UNIT WITH LOW OIL PRESSURE.
- DO NOT** 'WINDMILL' UNIT IN EVENT OF ENGINE FAILURE (PROP SHAFT SHOULD BE LOCKED TO PREVENT 'WINDMILLING').
- DO NOT** ATTEMPT FINAL ALIGNMENT OF OUTPUT FLANGE AND PROP SHAFT COUPLING WHEN VESSEL IS IN DRY-DOCK.
- DO NOT** SHIFT TRANSMISSION UNLESS ENGINE IS AT IDLE SPEED.

SERVICE MANUAL
HY 400 &
HP 500
Direct drive
Transmissions

SERVICE MANUAL 1-YPDD-79
Printed January, 1980
All rights reserved

Capitol Gears, Inc.
349 NORTH HAMLIN AVE.
ST. PAUL, MINNESOTA 55104, U.S.A.

TABLE OF CONTENTS

	PAGE
SECTION 1. INTRODUCTION	
1.1 DESCRIPTION	1
1.2 OUTPUT ROATION	1
1.3 ACCESSORIES	1
SECTION 2. PRINCIPLES OF OPERATION	
2.1 POWER FLOW	2
2.2 CLUTCH AND GEAR CARRIER	2
2.3 HYDRAULIC SYSTEM	3
SECTION 3. INSTALLATION AND OPERATION	
3.1 UNCRATING AND HANDLING	4
3.2 PRELIMINARY INSTALLATION	4
3.3 INSTALLATION OF REVERSE GEAR	5
3.4 ALIGNMENT	6
3.5 WATER PIPING	7
3.6 PUMP INSTALLATION	9
3.7 START-UP PROCEDURE	10
3.8 OPERATING PRACTICES	10
SECTION 4. PREVENTIVE MAINTENANCE	
4.1 LUBRICANTS	11
4.2 ROUTINE MAINTENANCE	11
4.3 MAINTENANCE SCHEDULE AND CHECK SHEET	12
SECTION 5. TROUBLE SHOOTING	
5.1 TROUBLE/REMEDY CHART	13
SECTION 6. REPAIR OF EXTERNAL SUBASSEMBLIES	
6.1 OIL PUMP	16
6.2 SELECTOR VALVE AND RELATED PARTS	19
SECTION 7. REPAIR OF INTERNAL SUBASSEMBLIES	
7.1 REMOVAL OF REVERSE GEAR	21
7.2 TABLE: REPLACEMENT WEAR LIMITS	22
7.3 CLUTCH AND GEAR CARRIER	23
7.4 OUTPUT SHAFT AND RELATED PARTS	29
7.5 HOUSING PARTS	30
7.6 ADAPTER GROUP	30
SECTION 8. PARTS INFORMATION	
8.1 PARTS ORDERING PROCEDURE	32
8.2 UNIT RECORD	32
8.3 ADAPTER GROUP	33
8.4 HOUSING AND RELATED PARTS	35
8.5 OUTPUT SHAFT AND RELATED PARTS	37
8.6 OIL PUMP	38
8.7 SELECTOR VALVE AND REALED PARTS	42
8.8 CLUTCH	43
8.9 OIL COOLER	51
8.10 PROP COUPLING KIT	52
ADDENDUM	
INSTALLATION PLANS	
CROSS-SECTION ASSEMBLY DRAWING	

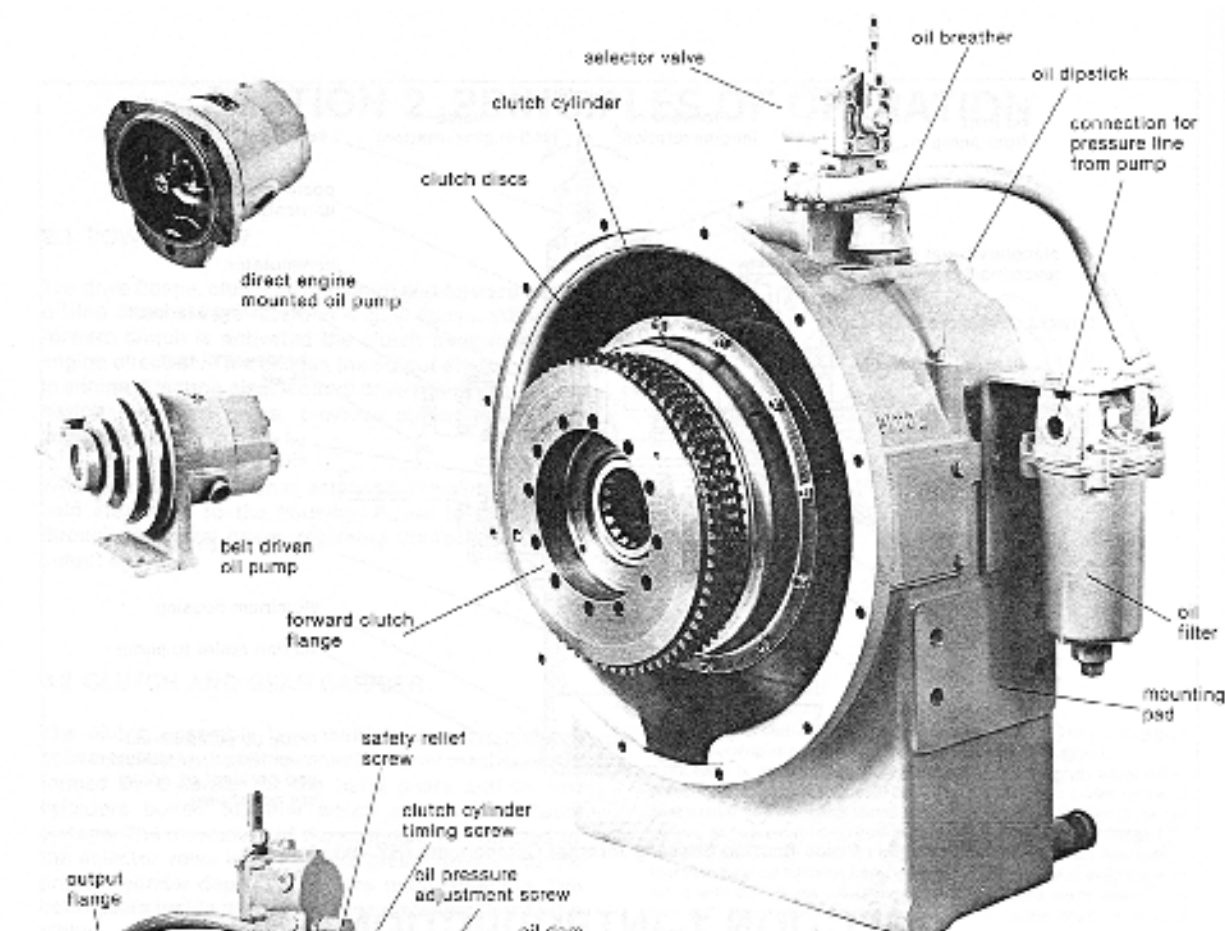

Figure 1. Model HY 400 Direct Drive Transmission-Front View

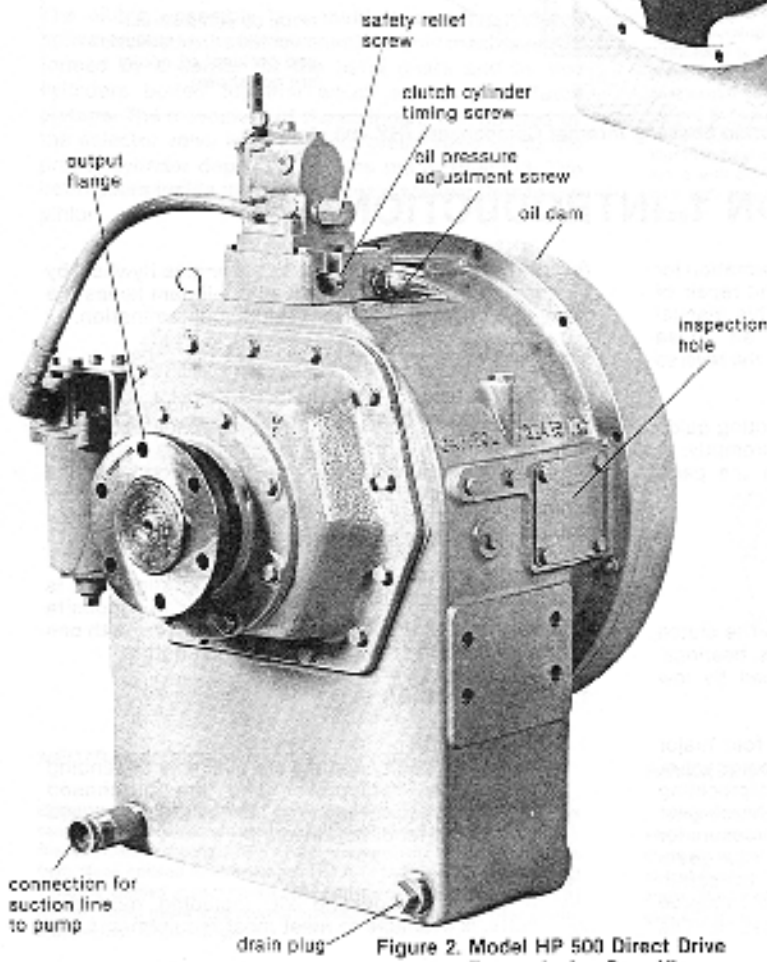
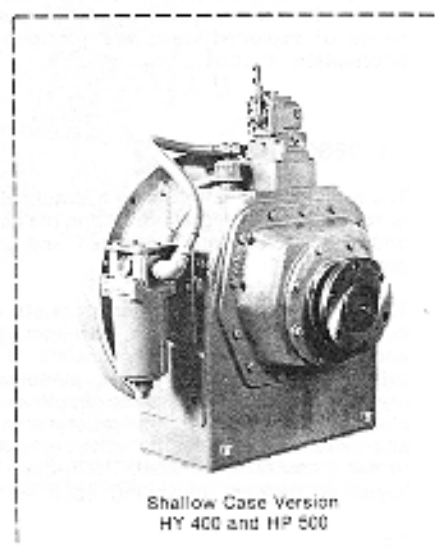

Figure 2. Model HP 500 Direct Drive Transmission-Rear View



Shallow Case Version HY 400 and HP 500

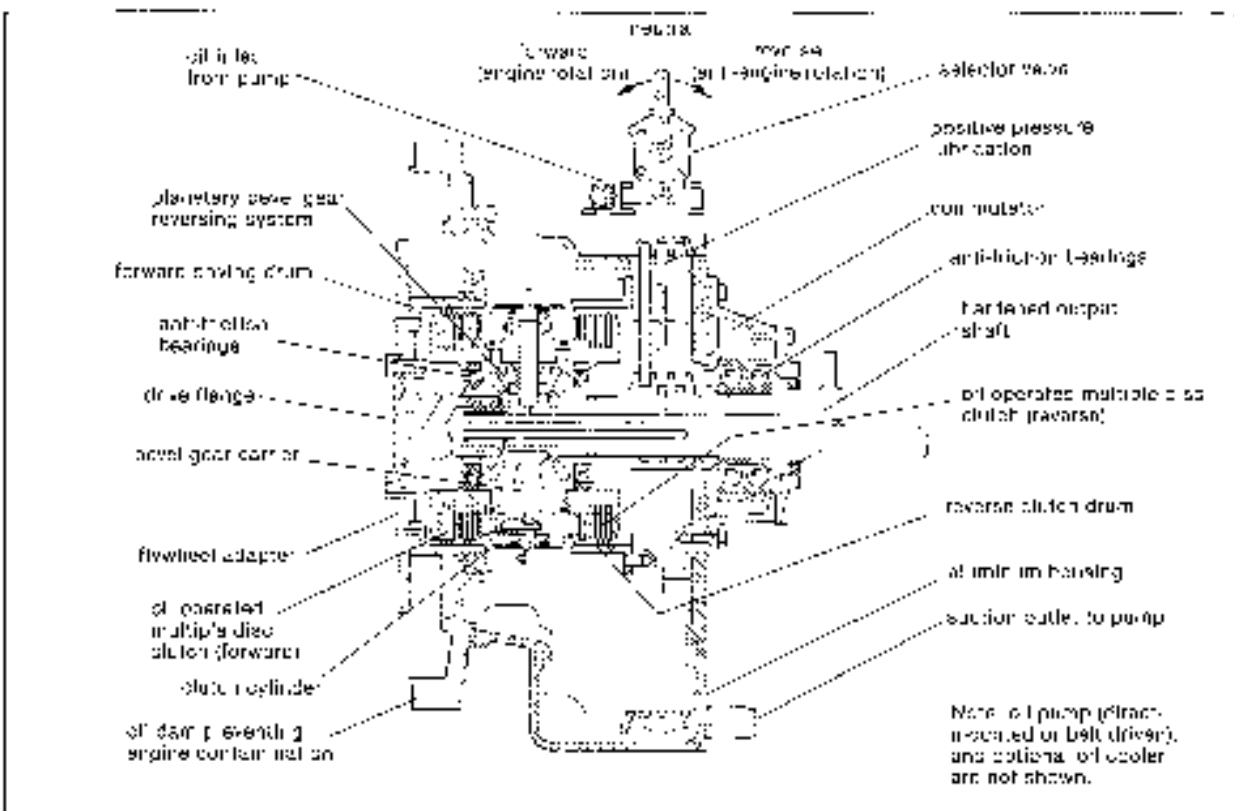

Figure 3. Cross-Section Showing Internal Components (HY 400 shown).

SECTION 1. INTRODUCTION

The function of this manual is to provide information for the installation, operation, maintenance and repair of the "CAPITOL" direct drive reverse gear. This manual should be made readily available to all those responsible for the operation or servicing of the reverse gear.

This service manual contains a troubleshooting guide, which will aid in assessing difficulties promptly. A series of exploded views are provided in the parts information section.

1.1 DESCRIPTION

The transmission is operated hydraulically; the clutch is activated by high-pressure oil and the gears, bearings, and clutch discs are lubricated and cooled by low-pressure oil.

The direct drive transmission consists of four major subassemblies; clutch pack, oil pump, selector valve and shaft. The clutch pack consists of reciprocating cylinders, clutch discs, and a planetary bevel gear reversing system. The oil pump supplies oil pressure the clutch engagement and lubrication for bearings, gears and clutch. The selector valve is used to obtain forward, neutral or reverse. The output shaft may be keyed or flanged depending upon application. The reverse gear is direct mounted to the engine flywheel by means of a flywheel adapter and an oil dam keeps the transmission sump free from engine contamination.

1.2 OUTPUT ROTATION

The capitol reverse gear in forward mode provides the output rotation in the same direction as engine rotation. The transmission is normally supplied for a right hand engine (clockwise when viewed from the front). When a unit is supplied for a left hand (counterclockwise) engine a pump of counterclockwise rotation is normally required also. (See pages 9 and 18R for details.)

For marine application, a twin screw arrangement is possible, provided the engines rotate in opposite direction, or if final drive is through vee drives, with one containing an idler for opposite rotation output.

1.3 ACCESSORIES

OIL COOLER

Various capacity coolers are available depending on engine horsepower and are purchased optionally. However oil cooler must be used with a Capitol drive unit.

COUPLING KIT

A prop shaft coupling kit, including mounting bolts, is available to meet most requirements.

SECTION 2. PRINCIPLES OF OPERATION

2.1 POWER FLOW

The drive flange, clutch driving drum and forward clutch driving discs always rotate at engine speed. When the forward clutch is activated the clutch pack rotates in engine direction. This causes the output shaft to rotate in the engine direction also. A direct drive transmission, not having reduction gears, provides output rotation at engine speed.

When the reverse clutch is activated, the clutch pack is held stationary to the housing. Power is transferred through the bevel gears, reversing the rotation of the output shaft.

rev
sp^t

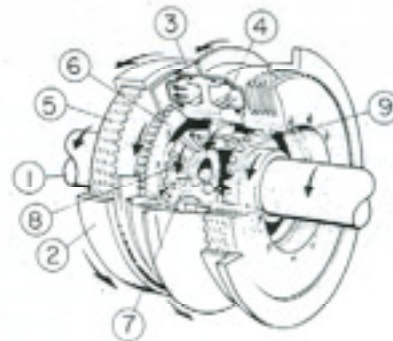

2.2 CLUTCH AND GEAR CARRIER

The clutch assembly is a multiple disc type clutch activated by a hydraulic mechanism. This mechanism is formed by a carrier for the bevel gears and by two cylinders bolted together which act as the clutch pistons. The movement of the cylinders is regulated by the selector valve, which directs pressurized oil to the proper cylinder depending on the mode selected. The bevel gears inside the carrier transmit power flow to the pinion.

FORWARD MODE

At all times, study shaft (1), forward driving drum (2) and driving gear (8) are turning in engine rotation direction, at engine speed. Forward is achieved when selector valve is shifted to allow oil to pressurize forward half of cylinder (3). Cylinder then slides on bevel gear carrier (4) clamping clutch discs (5) together. Half of discs are splined to forward driving drum and half are splined to end flange (8). Because end flange is bolted to gear carrier and discs are now locked together, gear carrier with bevel gears (7) now rotates at engine speed along with driving gear. Rotating bevel gears cause driven gear (9) to turn with them and this causes rotation of output shaft in forward rotation.

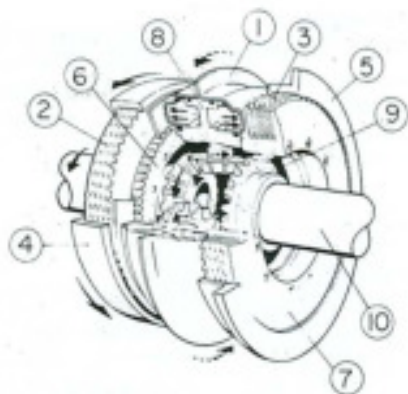

NEUTRAL MODE

Both halves of clutch cylinder (1) are filled with pressurized oil. Cylinder cannot press against either forward (2) or reverse clutch discs (3). Discs splined to driving drum (4) and reverse drum (5) remain separate from discs splined to end flanges (6)&(7). Consequently no direct torque is applied to gear carrier (8) or driven gear and output shaft (9) & (10). Bevel gears may

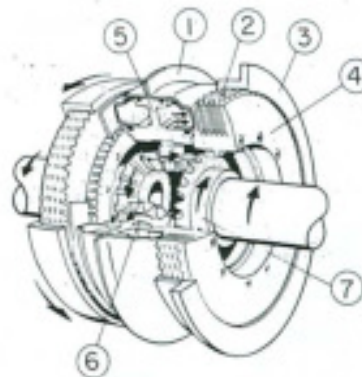

REVERSE MODE

Reverse is achieved when cylinder (1) is pressurized and slides against reverse clutch discs (2) clamping them together. Half of the discs are splined to the stationary reverse drum (3) and half are splined to end flange (4) bolted to gear carrier (5). Rotating gear carrier then stops. The bevel gears (6) now rotate on their shafts causing driven gear (7) to turn in anti-engine direction producing reverse output.

2.3 HYDRAULIC SYSTEM

Pressurized oil is provided by a gear type oil pump which is engine driven. From the pump oil flows through a cooler and filter before reaching the selector valve. Forward neutral and reverse are obtained by means of the selector valve, which directs high-pressure oil through internal passages to the clutch. Low-pressure oil is channeled to cool bearings gears and clutch discs.

In neutral, the ports to both forward and reverse dies of the clutch cylinder are opened and the balanced pressure that results keeps the cylinder from activating either forward or reverse discs. Oil is distributed through the lubrication system.

When the selector valve is shifted to either forward or reverse mode, high-pressure oil is allowed to flow only to one half of the clutch cylinder to engage the selected pack. Oil in the other half of the cylinder is exhausted to sump. Again low-pressure oil is distributed through the lubrication system.

An oil dam completely separates the transmission lubrication system from the engine lubrication system.

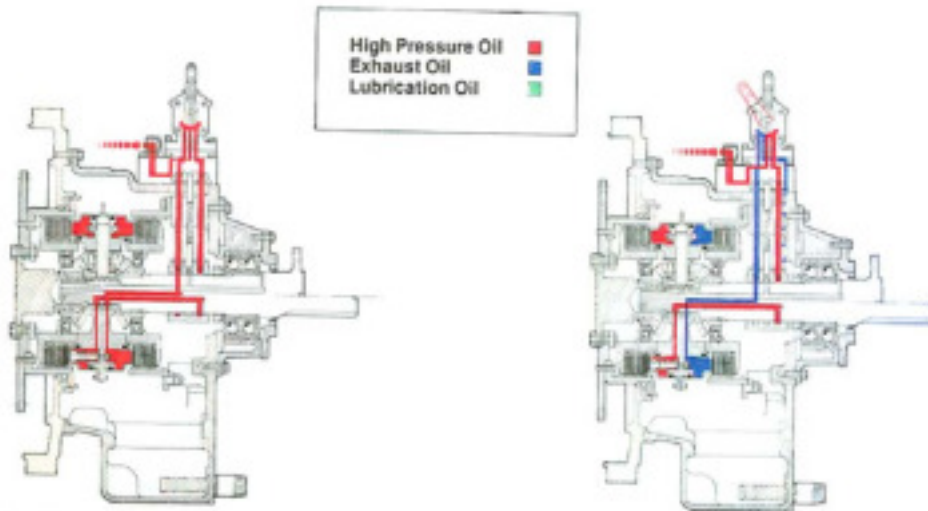

Fig. 4 NEUTRAL
Clutch Pressure Circuit (no exhaust)

Fig. 6 FORWARD
Clutch Pressure and Exhaust Circuit

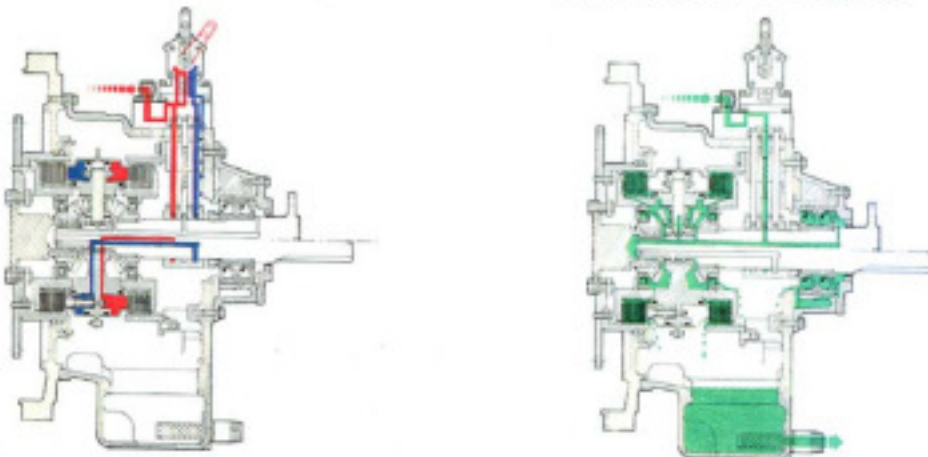

Fig. 5 REVERSE
Clutch Pressure and Exhaust Circuit

Fig. 7 LUBRICATION

SECTION 3. INSTALLATION AND OPERATION

3.1 UNCRATING AND HANDLING

Tapped holes have been provided for insertion of lifting hooks to aid in handling the unit. Average weight of HY 400 is 700 lbs; the HP 500 is 850 Lbs.

Check parts for shortage and any damage that may have occurred (the parts information section may be used as reference). Report immediately any shortage or damage to your local distributor, transfer agent or Capitol gears.

3.2 PRELIMINARY INSTALLATION

SPECIAL TOOLS REQUIRED

1. Chain hoist or equivalent
2. Straight edge
3. Feeler gauge
4. Thousandths dial indicator

To insure proper alignment of driving member it is recommended that engine flywheel housing, flywheel, oil dam and stub shaft be dial indicated to insure trueness.

1. (Fig.8A) Dial indicated the bolt face of the engine flywheel-housing flange. Rotate engine flywheel. Record reading. Face deviation must not exceed a **total indicator reading** of .007 inch.

2. (Fig.8B) Mount indicator with stem riding on flywheel housing bore as shown. Rotate flywheel and record reading. The bore eccentricity must not exceed a **total indicator reading** of .007 inch.

3. (Fig.8C) Mount indicator to flywheel housing so that stem is on inner face of flywheel, record deviation of face run out. It must not exceed a **total indicator reading** of .007 inch.

4. (Fig.8D) Set stem to ride on the pilot bore of the engine flywheel as shown. Record reading. Pilot bore eccentricity must not exceed a **total indicator reading** of .007 inch.

The sum total of all readings in steps 1 through 4 must not exceed .007".

NOTE:

Keep all mating surfaces clean. Use cleaning solvent or diesel fuel.

5. Separate the clutch driving drum and flywheel drive flange assembly from the clutch assembly.

Remove clutch-driving drum from the flywheel drive flange. Leave stub shaft attached.

6. Thoroughly clean the drive flange to flywheel mating surface and secure drive flange to fly wheel.

7. Bolt on flywheel adapter and stub shaft assembly to engine flywheel.

8. Secure oil dam on engine flywheel housing with 2 capscrews. "Top" mark goes up, or drain slots down.

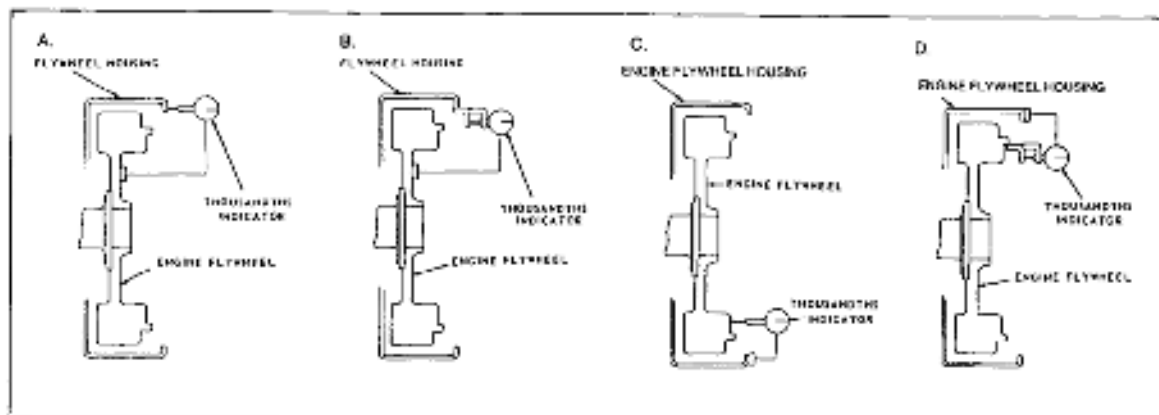

Figure 8. Dial Indicating Engine Flywheel and Flywheel Housing

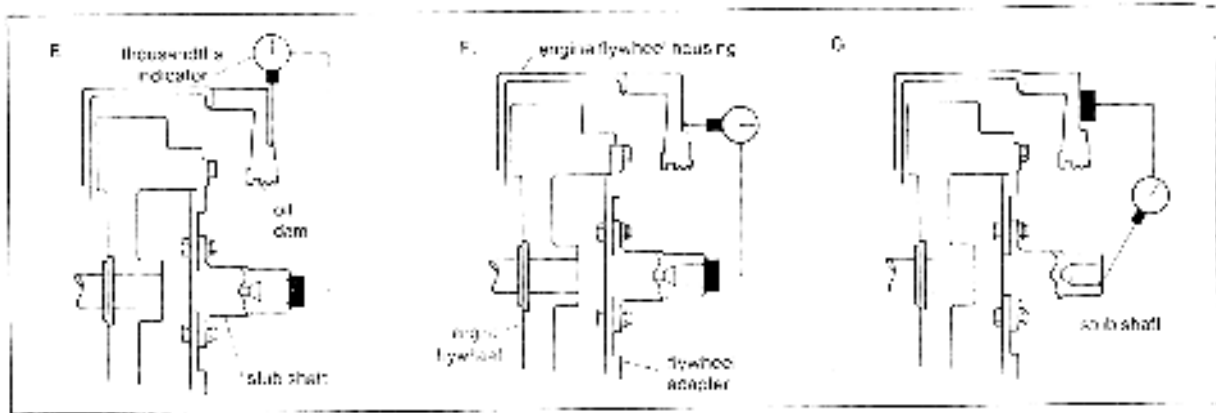

Fig. 9. Dial Indicating Oil Dam and Stub Shaft.

9. Dial indicate rear oil dam pilot O.D. as shown in figure 9E and dial indicate bolt face as shown in figure 9F. Record both readings. Total indicator readings must not exceed .007".

10. Dial indicate stub shaft as shown in figure 9G. Record the reading. Total indicator reading must not exceed .007 inch.

The sum of all readings in steps 9 and 10 must not exceed .007 inch.

11. If slinger shield is present on unit, remove slinger shield.

12. Installation clutch driving drum on flywheel adapter healing with #2 permatex.

13. Check clearance between drive flange O.D. and oil dam ID with feeler gauge. Minimum clearance must not be less than .006". Secure with self-locking fasteners.

14. Reassemble slinger shield, if present, to oil dam, replace and tighten cap screws. Secure cap screws with lock wire.

15. Place sub-assembly consisting of clutch and gear carrier in position on splines of driving stub Shaft. **NOTE:** The forward pack contains the greater number of discs and it goes toward the engine. Also the forward end flange is stamped "this side toward engine".

16. Remove the side inspection covers to facilitate installation.

3.3 INSTALLATION OF REVERSE GEAR

1. Using suitable hoist, lift reverse gear assembly into position behind engine. Ease unit forward over clutch assembly, taking care that clutch discs enter reverse clutch drum properly so that teeth are not damaged.

2. Secure main housing to oil dam housing, tighten capscrews to 42 pounds-foot torque (HY units) and 29 pounds-foot torque (HP units).

Check clutch end float

- a) Insert screwdriver through side inspection Hole and pry clutch fore and aft. End float should be 1/16" and 3/32".
- b) Replace gasket and inspection covers.

3. Turn output shaft over for several revolutions making sure unit is free to turn

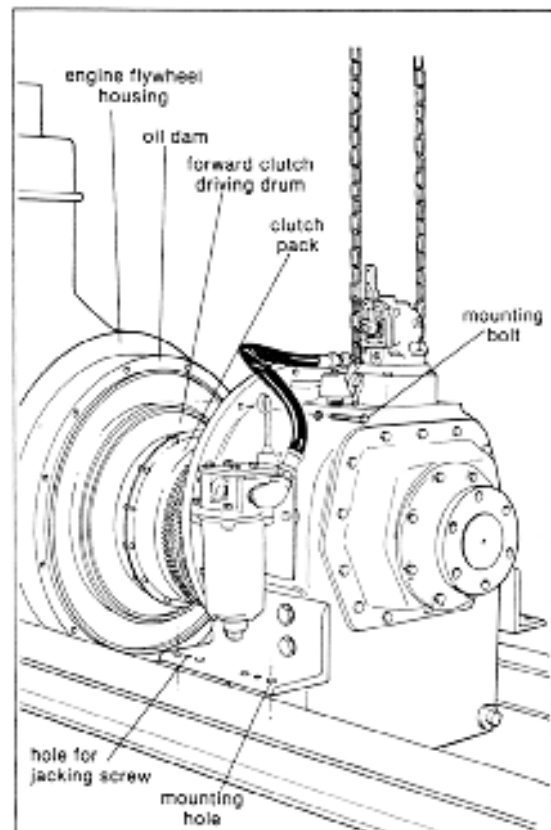

Fig. 10. Installing Reverse Gear

NOTE:

Use screwdriver through side inspection hole and move disc teeth to align with reverse drum.

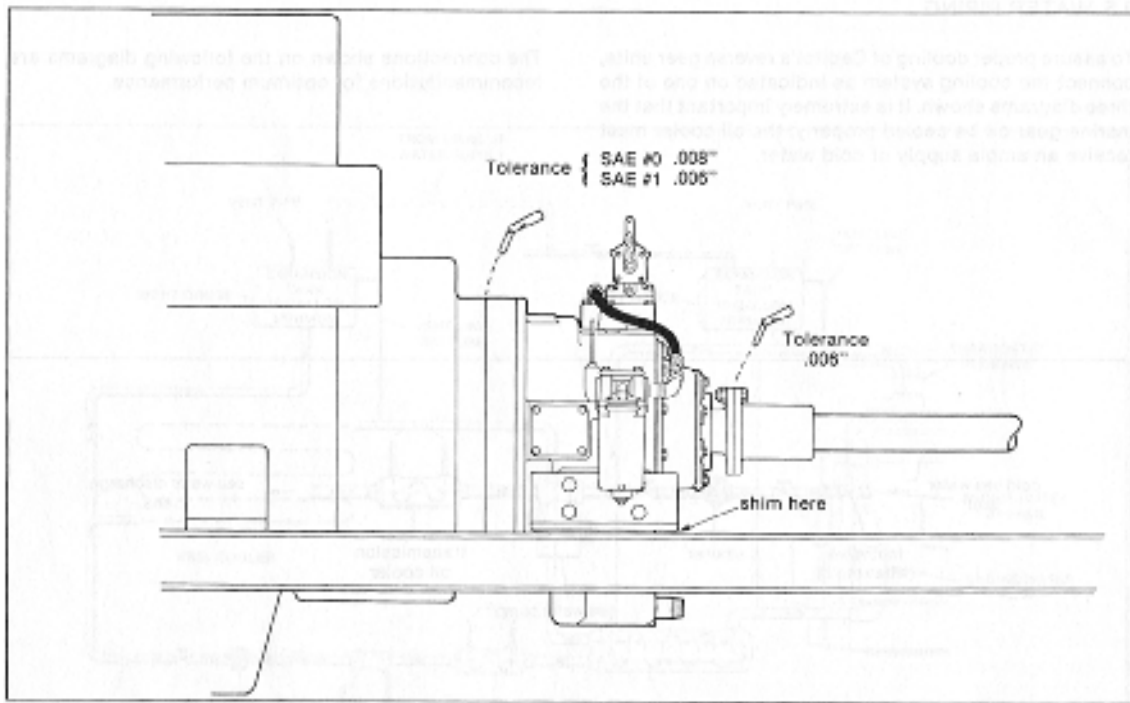

Fig. 11. Alignment of the Engine and the Reverse Gear

In marine application, final alignment of output flange and propeller shaft coupling must be accomplished when the vessel is afloat and not in dry-dock, because most hulls will flex. This is positively necessary to meet warranty requirements.

Mounting pads on housing permit unit to be bolted to be rails, power plant frame, keelsons, etc.

The distance of the first shaft bearing from the mating surface of the reverse gear output coupling is extremely important. To avoid undue force on the reverse gear bearings, the propeller shaft bearing should be located at least twelve and preferably twenty shaft diameters from the reverse gear output coupling.

NOTE:
The same alignment procedure should be followed even if a flexible coupling is used. The most accurate method is to use a non-flexible spacer of the same size. Flexible couplings are used only to dampen-noise and vibration not to correct misalignment.

Now align shaft coupling to reverse gear coupling. Lay a straight edge across the edges at top and sides to line up couplings. Do not burr or mar mating surfaces. Insert feeler gauge between couplings and run it all around the flange. Clearance should not be more than .006" at any pint. Shim engine and reverse gear as necessary.

Loosen gear housing to engine housing bolts and check with feeler gauge. Maximum variation for SAE #0 housing .008"; for SAE #1 housing .006".

Tighten four gear housing capscrews at 90° intervals. Secure engine and gear mounting feet. Loosen four gear-housing bolts. Recheck housing and coupling parallelism. If within limits tighten hosing and coupling bolts.

NOTE:
Under no condition is the engine to be supported by gear housing.

3.5 WATER PIPING

To assure proper cooling of Capitol's reverse gear units, connect the cooling system as indicated on one of the three diagrams shown. It is extremely important that the marine gear oil be cooled properly; the oil cooler must receive an ample supply of cold water.

The connections shown on the following diagrams are recommendations for optimum performance.

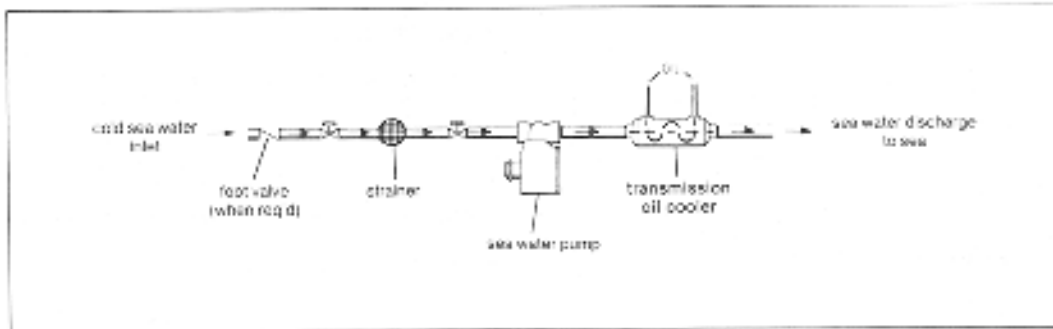

Fig. 12. Separate pump system

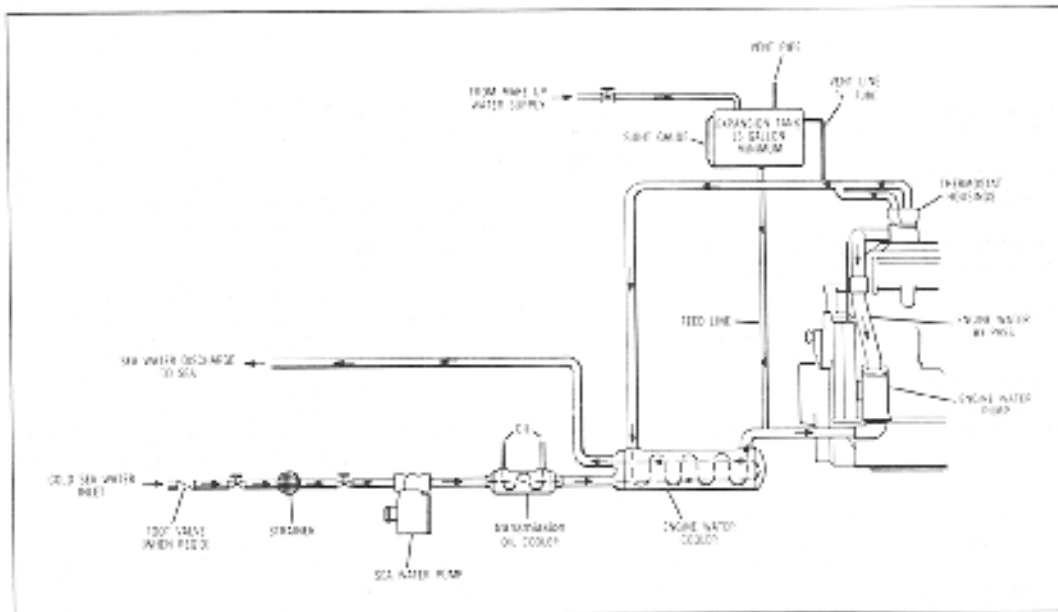

Fig. 13. Heat exchange system

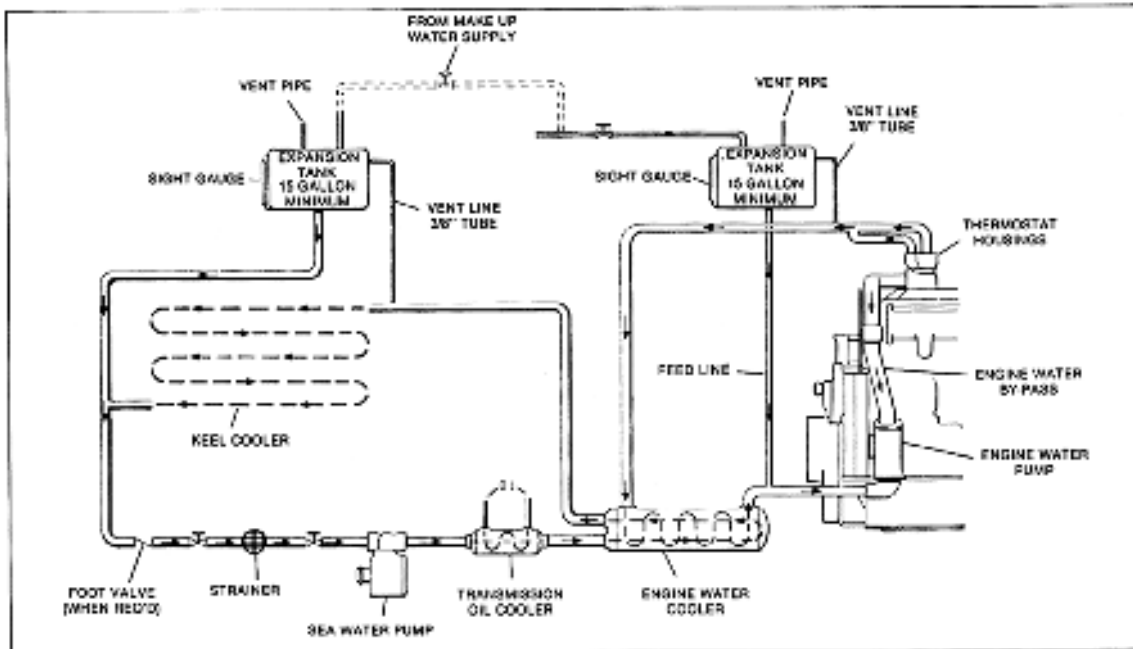

Fig. 14. Keel cooler system

3.6 PUMP INSTALLATION

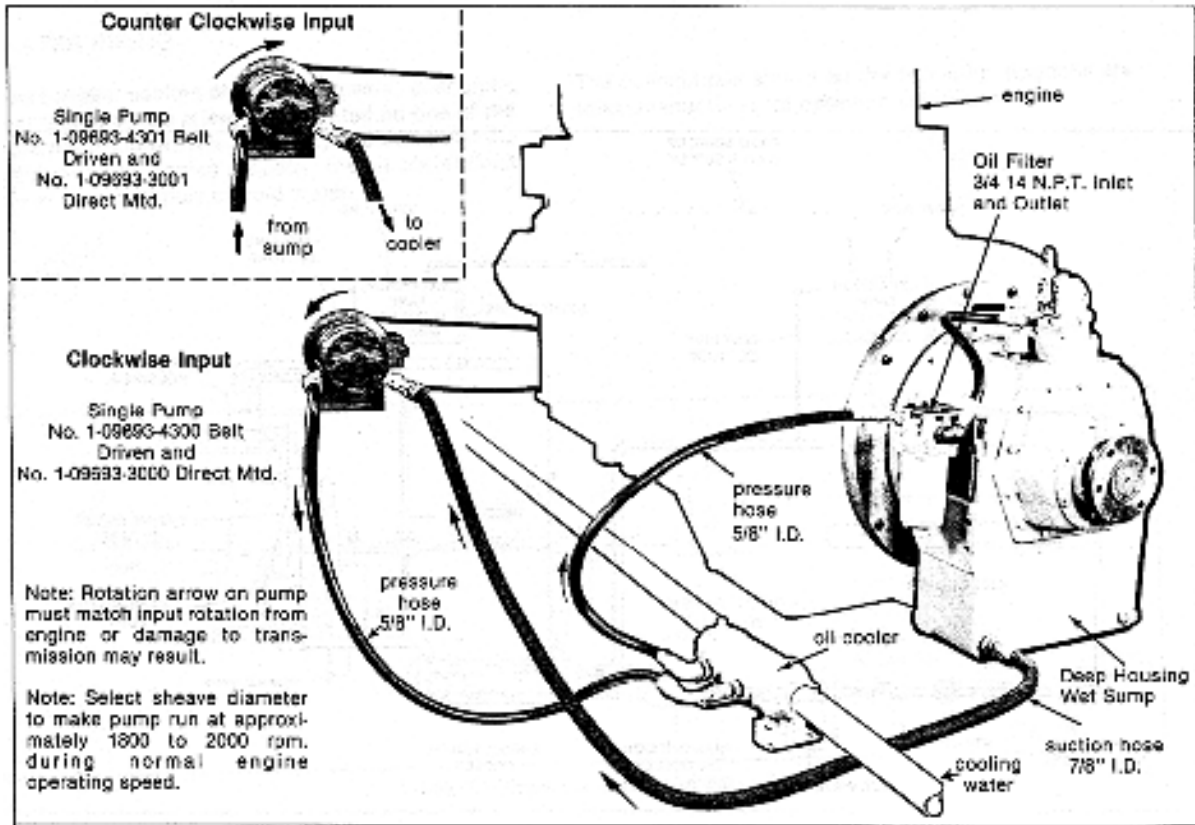

Fig. 15. Single Pump Connections

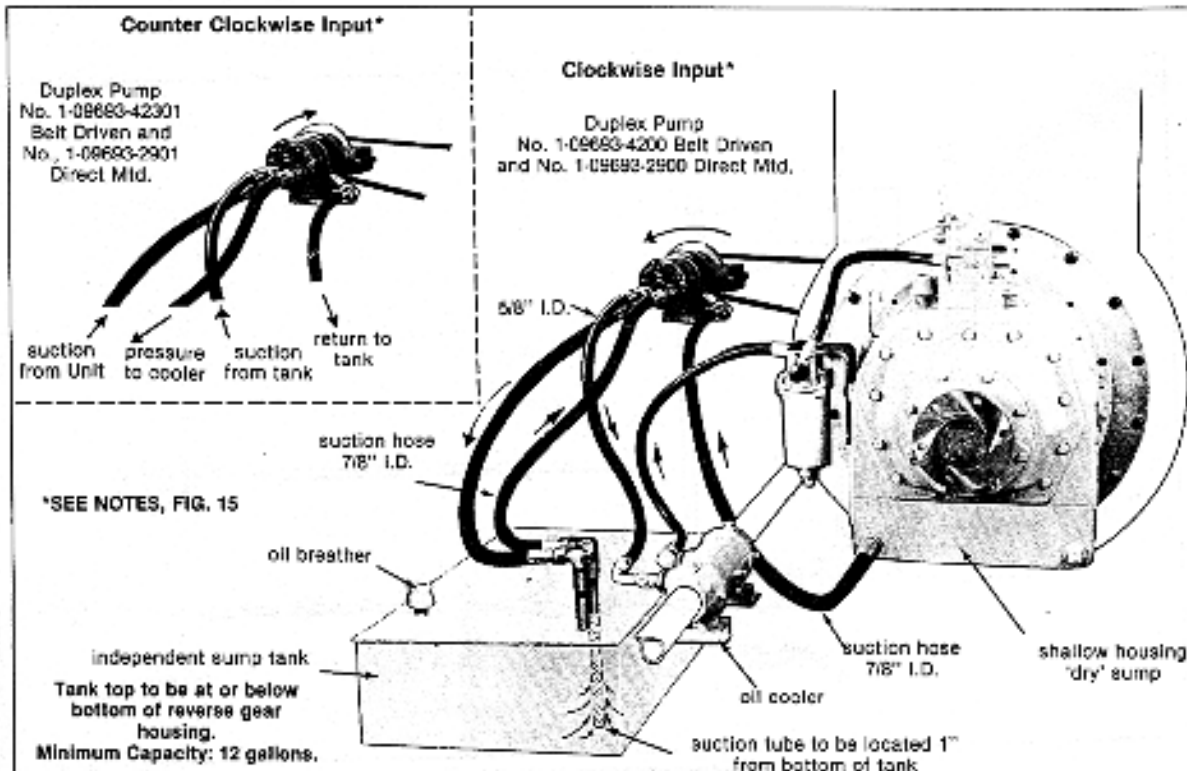

Fig. 16. Duplex Pump Connections

3.7 START-UP PROCEDURE

1. Remove reverse gear inspection cover and pour in recommended oil until level is up to full mark on dipstick (see lube chart). Replace inspection hole cover but do not secure.
2. Install pressure gauge of 300-pound capacity directly on top of gear or on bulkhead. Connect gauge to control valve with 1/4" steel tubing or hydraulic hose. (Note: Electric type oil pressure gauges are not recommended.)
3. Engage starter for approximately 30 seconds. (NO NOT START ENGINE). This activates pressure pump which pre-lubricates reverse gear, preventing premature wear before load is applied.
4. Start engine and check all connections for leaks.
5. Oil pressure is adjusted at factory for testing purposes only and it may be necessary to readjust pressure to the correct level (200-210 PSI). This should be done at normal operating speed and temperature.
6. After unit has been operated a few minutes, stop engine, check oil level and add sufficient oil to bring level to full mark on dipstick. (See lube chart for capacities, p.11).
7. Shift several times to insure that all cylinders, hoses and cooler are full of oil.
8. Install selector valve cables and shift to insure valve lever goes into full detent in all 3 positions: forward, neutral and reverse.

NOTE:
Normally, unit pressure at idle start-up will be 180 PSI, but final adjustments must be made as noted above. See figure 17 below.

NOTE:
We strongly recommend installing an interlock control system which prevents shifting at other than engine idle speed and greatly prolongs life of the gear.

9. Reverse gear is now ready for sea trials and final adjustment.

3.7 OPERATING PRACTICES

(CAUTION)

1. A Capitol reverse gear should not be shifted unless engine is at idle speed.
2. Reverse gear cannot be operated continuously in reverse mode for more than 30 minutes at 75% of available horsepower.
3. In marine application 'wind milling' (freewheeling) is strictly prohibited at extensive internal damage may result. IN the case of a twin-screw application where only one engine may be used a great deal, shaft brakes should be installed. (As an alternative an auxiliary lube system may be installed).

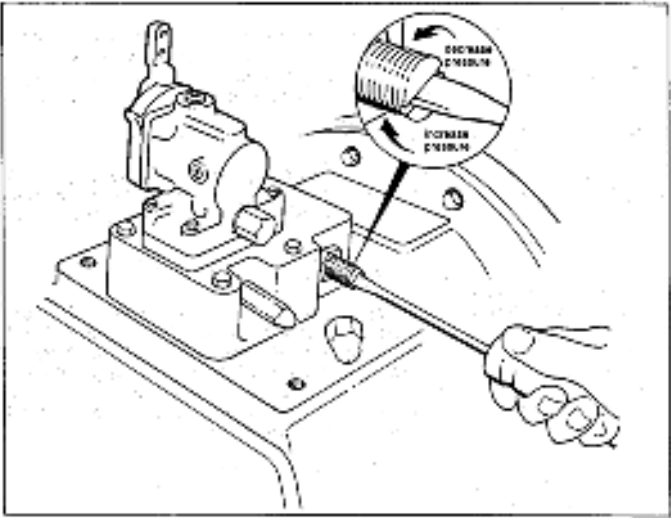

Fig. 17. Adjustment of oil pressure

**CORRECT
OIL PRESSURE:
200-210 P.S.I
At normal
operating speed
and temperature.**

SECTION 4. PREVENTIVE MAINTENANCE

To insure a long service life of the Capitol direct drive gear and to prevent costly and unexpected failures it is very important that a regular maintenance schedule be established and followed.

4.1 LUBRICANTS

For all normal ambient operating conditions, 30°F, (-1°C) to 85°F (29°C), we recommend a good grade, anti-foaming, heavy duty, SAE 30 motor oil.

Where high ambient water temperatures are encountered, over 85°F (29°C), it may be necessary to use SAE 40 motor oil.

Where extreme cold ambient water temperatures are encountered, under 30°F (-1°C), it may be necessary to use SAE 20 motor oil.

Series 3 motor oils are not recommended as they may shorten clutch life.

CAUTION:

When using SAE 20 motor oil be very attentive to oil pressures. If proper pressure cannot be maintained (200-210 P.S.I.), it may be necessary to use SAE 30 and warm engine and gearbox thoroughly before engaging clutch. This condition would only be encountered at extremely low temperatures.

Oil Capacity

HY 400 and HP 500 (deep case models) 18 quarts or more depending on hose length and cooler capacity.

Bring oil up to full mark on dipstick. Operates unit in forward reverse for several minutes. This will fill cooler, clutch cylinders, pump hoses, etc. Stop engine and add required oil to return level to "full" mark on dipstick.

Oil pressure

Operating oil pressure should be 200-210 PSI at normal operating speed and maximum operating temperature.

Pressure adjustment
See fig. 17, page 10.

Oil Temperature

Operating oil temperature range is 160°F. (71°C) at control valve, 160° to 180° (82°C) at sump.

4.2 ROUTINE MAINTENANCE

Oil Cooler Assembly

Check zinc pencils in oil cooler and change if badly eroded. Check zinc pencils at approximately **every 400 hours** of operation.

Check water tubes for obstructions at approximately **every 2000 hours** of operation and flush if necessary.

Oil Filter

The oil filter element should be replaced every 400 hours of operation or at the same time oil is changed.

Oil Breather

Remove oil breather **every 400 hours** of operation or at the same time oil is changed. Clean diesel fuel can be used for flushing.

Pressure Gauge

Periodically check pressure gauge by substituting a calibrated pressure gauge of known accuracy.

Visual Inspection

At frequent intervals check all oil lines, water hoses, and connections for leaks. Tighten all external bolts and connections and visually inspect external components for wear or damage.

Wear Analysis

At periodic intervals record pressure readings at idle speed, a gradual decline is normal. Readjust pressure relief valve to maintain proper operating pressures. See fig. 17, p.10.

Inspection/ Overhaul interval

A complete inspection of the Capitol reverse gear should be made at least as often as the engine is overhauled. Parts such as commutator bushings, oil seals, quad rings, clutch discs, bearings, etc. Showing any fatigue or wear should be replaced. It may be desirable to completely rebuild the reverse gear at this time (see section 6 and 7.)

SECTION 5. TROUBLE SHOOTING

5.1 TROUBLE/REMEDY CHART

<u>SYMPTOM</u>	<u>PROBABLE CAUSE</u>	<u>REMEDY</u>
A. Low oil pressure (at full operating speed and temperature.)	1.Low oil level	Inspect gaskets, seals, hoses and fittings for leakage. Remove suction screen and clean with a good grade solvent or diesel fuel. Replace element.
	2.Clogged suction screen.	
	3. Clogged filter element	
	4. Dirt or sludge in transmission.	Remove drain plugs, flush gear with commercial solvent or diesel fuel. Start engine; at idle shift gear several times, full forward to full reverse for approx. 5-7 min. Shut down engine and drain gearbox thoroughly. Refill gear with proper oil and run for approximately 25-50 hours. Drain sump and refill with new oil. This will remove any residual solvent.
	5. Worn or incorrect adjusted pump assembly.	Refer to oil pump section (page 17) or fig. 17, p.10.
	6. Oil too hot	Check heat exchanger system for clogged oil cooler or hoses.
	7. Worn commutator bushings	See wear limits chart (p.22)
	8. Incorrect lubricant	See lube chart (p.11)
	9. Scratched clutch cylinders or hard O'rings in clutch cylinders.	Replace as necessary. (P.25)
B. High oil pressure (at full operating speed and temperature)	1. Incorrectly adjusted pump assembly.	1. Refer to fig.17, p. 10
	2. Inoperable relief plunger in base plate.	2. Refer to, p. 20
	3. Incorrect oil	3. See lube chart (p.11)
	4. Oil too cold	4. Check heat exchanger system
C. Overheating	1. Insufficient oil cooler capacity	1. Install adequate oil cooler
	2. Insufficient flow of cooling water.	2. Increase water line sizes.
	3. Clutch slipping	3. Refer to symptom A.
	4. Water temperature too high at cooler.	4.Decrease water temperature to cooler or relocate heat exchanger in cooling system.

D. Excessive noise in Transmission	1. Bearings worn or broken.	1. Inspect bearings for scored races, broken roller, flat spots, etc.
	2. Gears worn or broken	2. Inspect gears and replace if necessary
	3. Noise in forward only	3. Reverse position may be mistakenly used for forward. Selector valve lever must point forward when boat is in forward motion.
	4. Noise in reverse only	4. This is normal because more gears are in operation in reverse mode.
E. Noisy Pump	1. Dirt or sludge in oil	1. Remove oil pump and hoses. Clean Thoroughly and reinstall
	2. Clogged hoses	2. Clean and replace as required
	3. Pump Cavitation	3. Inspect suction hoses for leaks. Oil level may be too low
	4. Defective oil pump assembly	4. Refer to oil pump section p. 16
F. Clutch does not release	1. Improper oil in sump	1. Refer to lube chart, p. 11
	2. Clutch discs warped	2. Replace as necessary, see p. 26
	3. Forward and reverse clutch cylinders dirty or distorted	3. Clean or replace as necessary, see p. 25, 26
	4. Rear commutator bushing is worn	4. Replace as necessary, see wear limits, p. 22
	5. Clutch discs fused due to Slippage and over heating	5. Replace as necessary, see p. 26
G. Clutch slippage	1. Low oil pressure	1. See symptom A
	2. Oil temperature too high	2. Temperature should be 160°F (71°C), at selector valve, 160°-180° at sump check heat exchanger system.
	3. Worn clutch discs	3. Replace as necessary, see p. 26
	4. Improper oil	4. See lube chart, page 11
H. Clutch burned out	1. Low oil pressure	1. See symptom A
	2. Clutch is shifted at other than engine speed	2. Install interlock shift controls
	3. Transmission misaligned	3. Check alignment as described in installation section p. 4.
	4. Excessive heat	4. Check cooling system see p. 7

I. No neutral	<ol style="list-style-type: none"> 1. Warped clutch discs 2. Scored clutch cylinders 3. Damaged seal rings 4. Worn or damaged commutator bushings (forward or rear) 5. Worn selector valve 	<ol style="list-style-type: none"> 1. Replace as necessary, see p. 26 2. Replace as necessary see p. 26 3. Replace all seal rings see p. 25 4. Refer to repair section, p.23-25 or p. 29. See wear limits, p.22 5. Replace if necessary. Note: Selector valve is the least likely source of trouble, p.19
J. Delay in clutch engagement	1. Cylinder timing screw out of Adjustment	1. Remove dome nut and adjust screw (counter- clockwise) to speed up Reaction. See p. 23.
k. Clutch engages too fast	1. Cylinder timing screw out of adjustment	1. Remove dome nut and adjust screw in (clockwise) to delay reaction. See p. 23

SECTION 6. REPAIR OF EXTERNAL SUBASSEMBLIES

CAUTION

Avoid contact with rotating output coupling and always shut down engine when doing even minor inspection or repair. Avoid contact with metal surfaces as operating temperatures may exceed 200°F.

Capitol gasket and seal kit NO. 1-10195-0000 includes all necessary gaskets seals and o-rings for repairs on the HY 400 and HP 500 transmissions.

Gasket and seal kit No. 1-10196-0000 is designed for all torque converter (TC) models.

6.1 OIL PUMP

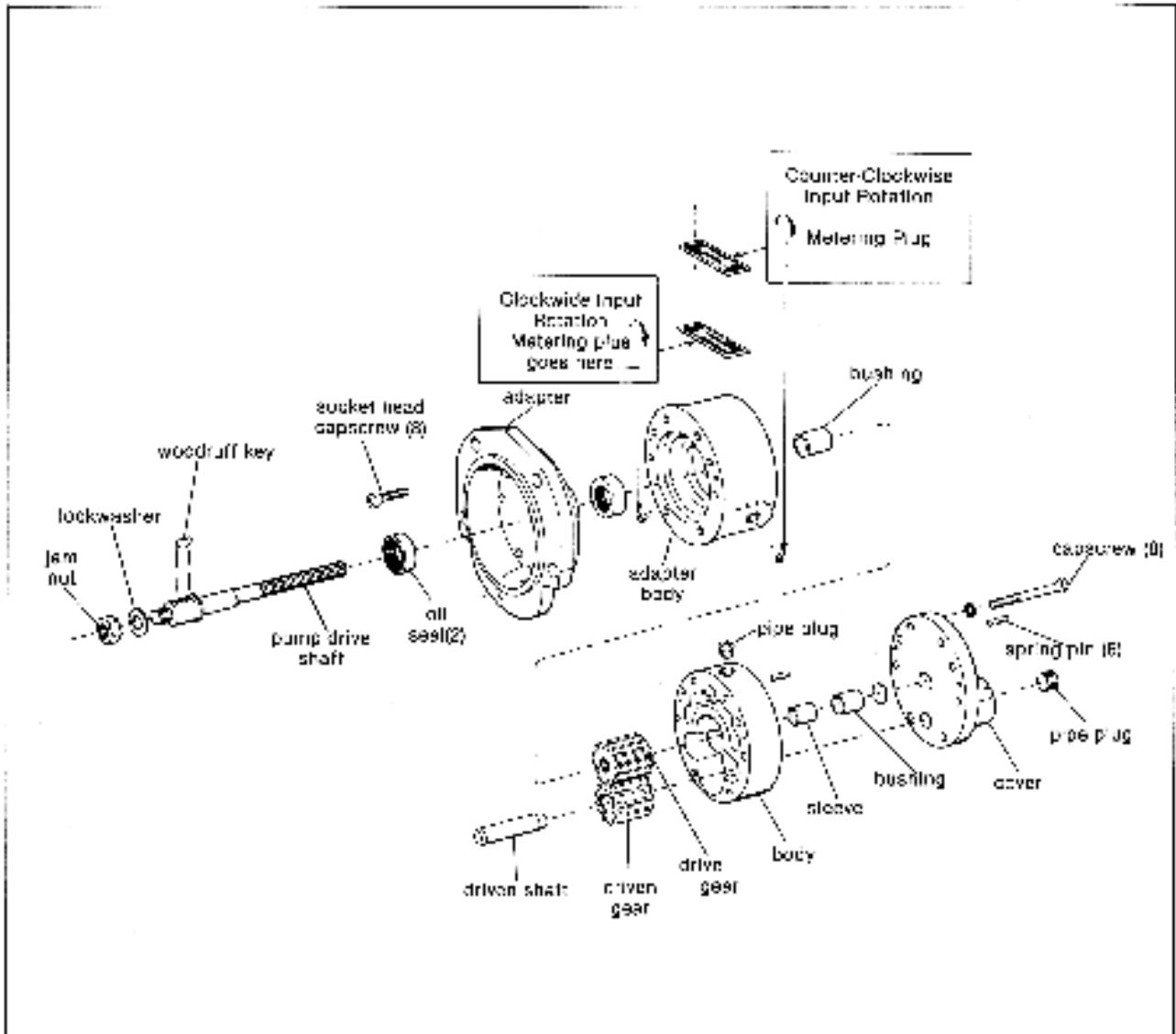

Fig. 18. Oil Pump; Single Direct Mount Style Shown.

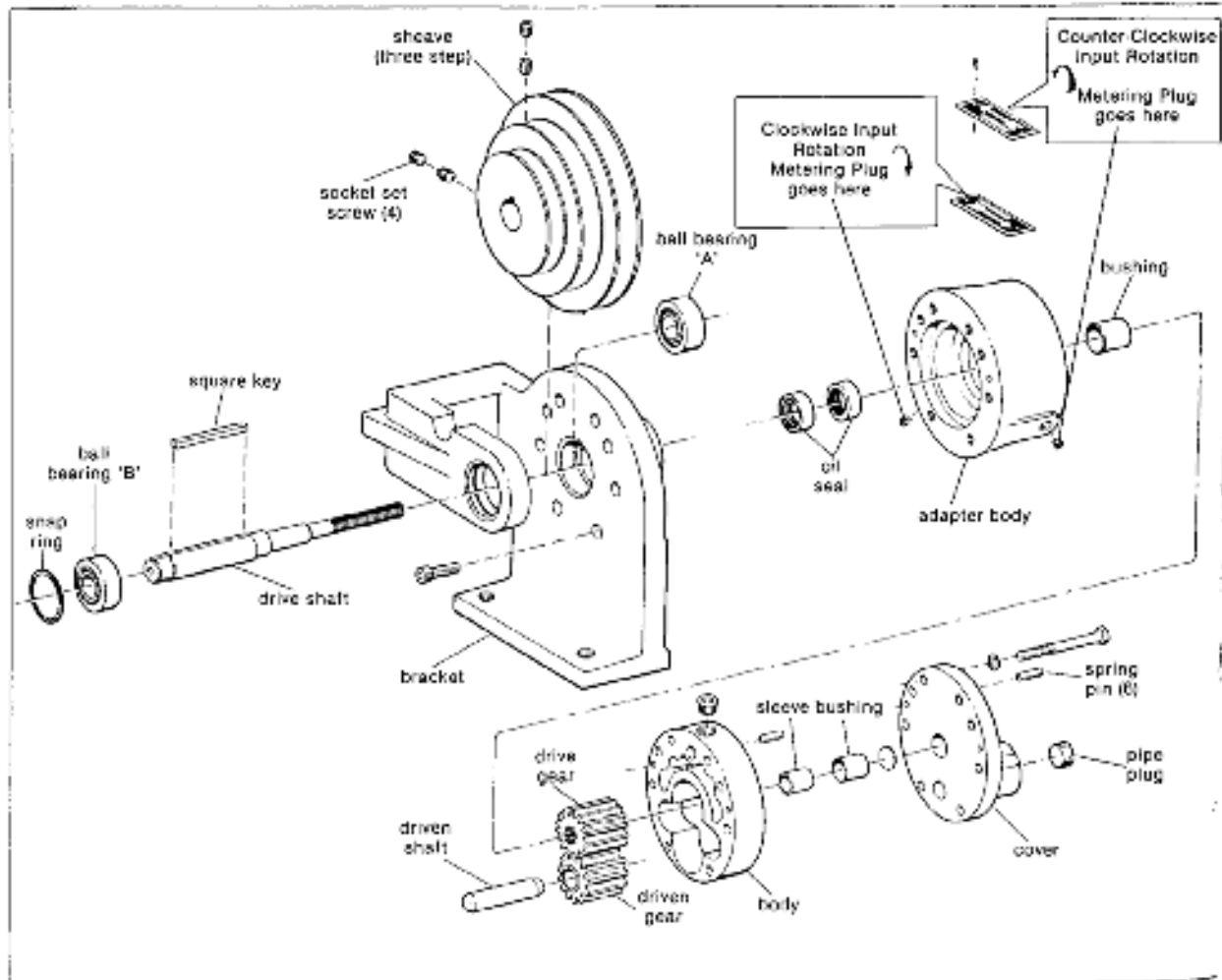

Fig. 19. Oil Pump; Belt Driven Single Style Shown

A. DISASSEMBLY

1. Disconnect hoses and remove mounting bolts securing pump
2. Remove capscrews in cover. Punch mark side of cover, body, and adapter body for reassembly. Separate parts with soft hammer.
3. Belt-driven pumps: remove socket set screws (4) then remove snap ring from bracket. From splined end tap pump shaft out of position With soft hammer.

Direct mounted pumps: Pull shaft through Adapter from keyed end.

4. Remove socket head capscrews (8). Remove and discard oil seals, remove pump gears, and remove driven shaft if wear is suspected.

B. CLEANING AND INSPECTION

1. Remove all permatex and clean all parts with cleaning solvent or diesel fuel. Blow parts dry with compressed air.
2. Inspect gears and oil pump body for damage or excess wear. See wear limits chart, p. 22.
3. Inspect cover and adapter body for wear caused by gears. If grooving does not exceed .020" surfaces can be ground smooth (.002" maximum cut)
4. Inspect sleeve and bushing in cover for wear, out of round condition or burrs. If they are damaged or if flat discs are worn or loose, replace them. (New bushing should be reamed to .627/ .628 ID)

5. Inspect bushing in adapter body. Replace if worn or damaged. New bushing should be reamed to .502/ .503 ID after being pressed in bore.
6. Inspect bushings in driven gear. Replace if necessary and ream new bushings to .627/ .628 ID.
7. Inspect all mating surfaces for smoothness.
8. Check each oil passage and the metered plug for obstruction.

C. RE-ASSEMBLY

Belt-Driven Pumps:

1. Install new oil seals (Metal face inward) In bracket.
2. Install ball bearing 'A' (see fig. 19)
3. Install driven shaft in adapter body (7/16" into bore).
4. Apply very thin * coat of permatex 'super 300' or equivalent to mounting faces and following punch marks place adapter body with bushing installed on bracket. Secure with socket head capscrews (8).
5. Hold sheave and drive belt in position in bracket and with keyway aligned slide drive shaft and key into place, splined end first. Install socket set screws (4) in sheave.
6. Tall ball bearing 'B' (see fig. 10) into bracket and secure with snap ring.
7. Generously lubricate pump gears with Vaseline, lubriplate, or engine weight oil. Slide driving gear onto pump drive shaft and driven gear onto driven shaft (in adapter body).
8. Apply a very thin *coat of permatex 'super 300' sealant or equivalent to mating surfaces and slide body over gears and onto adapter body following punch marks
9. Apply thin * coat of sealant and install cover following punch marks. Loose insert hex head capscrews. Install spring pins (6) flush with cover. Torque capscrews (8) to 16 lbs-ft.

Direct engine mounted pumps:

1. Install new oil seals in adapter (Metal face inward)
2. Install driven shaft in adapter body (7/16" into adapter bore.)
3. Apply a very thin *coat of permatex 'super 300' sealant to mating surfaces and secure adapter body (bushing installed) to adapter following punch marks. Torque socket head capscrews to 16 lbs-ft.
4. Install shaft in adapter spline end first
5. Lubricate pump gears with Vaseline, lubriplate or equivalent. Slide driving gear onto driving shaft and driven gear (bushings installed) following punch marks.
6. Apply thin coat * of 'super 300' permatex to mating surfaces and slide body over gears and onto adapter body, aligning punch marks.
7. Apply a thin coat * of sealant and install cover (bushing, disc and sleeve installed) following punch marks. Loose insert hex head capscrews. Install spring pins (6) flush with cover. Tighten capscrews to 16 lbs-ft torque.

***NOTE:**

Too much sealant can cause pump to malfunction and damage to reverse gear may result.

D. PUMP ROTATION

Input rotation to the pump must be the same as the rotation arrow on the pump itself indicates. If input rotation is changed the pump must change also. The metering plug must be moved to the opposite side and hoses must be reversed. The rotation arrow on the pump should be Changed also. (See page 9 for details)

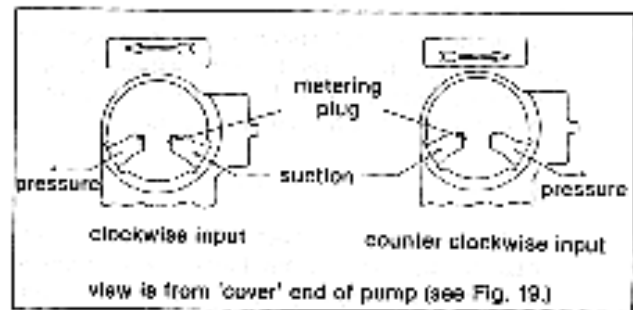

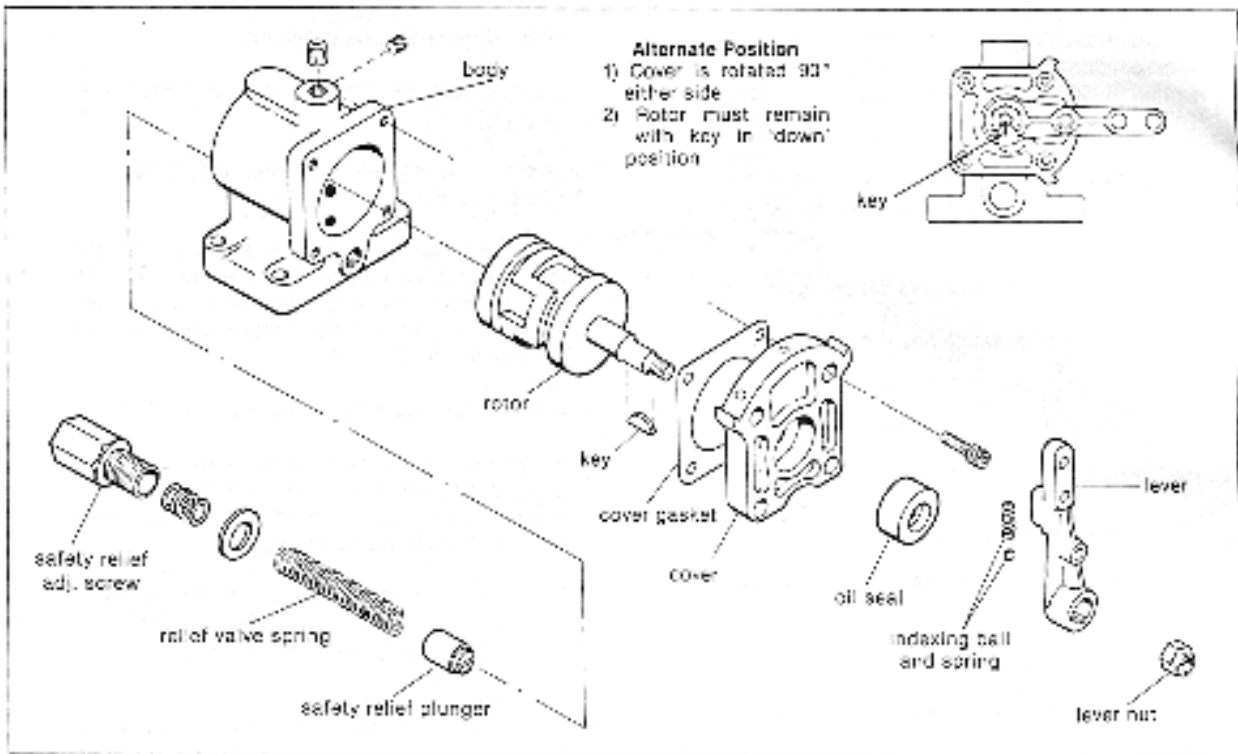

Fig. 20. Selector Valve Assembly

A. REMOVAL

1. Disconnect hoses and control linkage from lever on selector valve.
2. Remove capscrews and lock washers and lift off selector valve and base plate being very careful to keep gaskets in proper configuration for replacement. (they may be fixed in position with wire, etc.)

B. DISASSEMBLY

1. Remove lock nut from rotor and note position of keyways on lever to rotor. (Match mark if desired). Remove lever from rotor being careful not to lose indexing ball and spring.
2. Remove key from rotor shaft
3. (Note position of cover). Remove cover, cover gasket, and rotor from block. (Note relative position of keyway to rotor and lever, Matchmark if desired.)
4. Remove safety relief adjustment screw, washers, spring and plunger. **NOTE: SPRING IS UNDER TENSION.**

C. CLEANING AND INSPECTION

1. Clean all parts thoroughly with oil and clean all oil ports. Blow dry with compressed air.
2. Inspect rotor and valve block for scoring. Excessive scoring indicates replacement. Valves are not repairable.
3. Inspect oil seal in cover. If it is worn or shows evidence of leaking replace it.

D. ASSEMBLY

NOTE:
 On all fittings use permatex 'super 300' sealant, graphite paste, or equivalent. **CAUTION:** do not use No. 1 Permatex or Teflon tape.

1. If necessary install new seal in cover. Press seal in until it bottoms in bore (rubber face out). Apply lubricant to seal
2. Insert rotor shaft through oil seal in cover.
3. Set key in rotor shaft and install lever with Indexing ball and spring. Make sure that keyway in rotor shaft remains toward bottom of cover.
4. Tap control lever in position with a soft hammer and secure with lock nut.
5. Position new cover gasket on pilot face of cover.
6. Install rotor with cover into selector valve

body. Secure cover with four capscrews.
Tighten to 4 pounds-foot torque.

7. Install safety relief adjustment parts in rear of valve body

8. Check for correct assembly by moving lever back and forth. Selector valve is now ready to be installed on main housing. See fig. 21

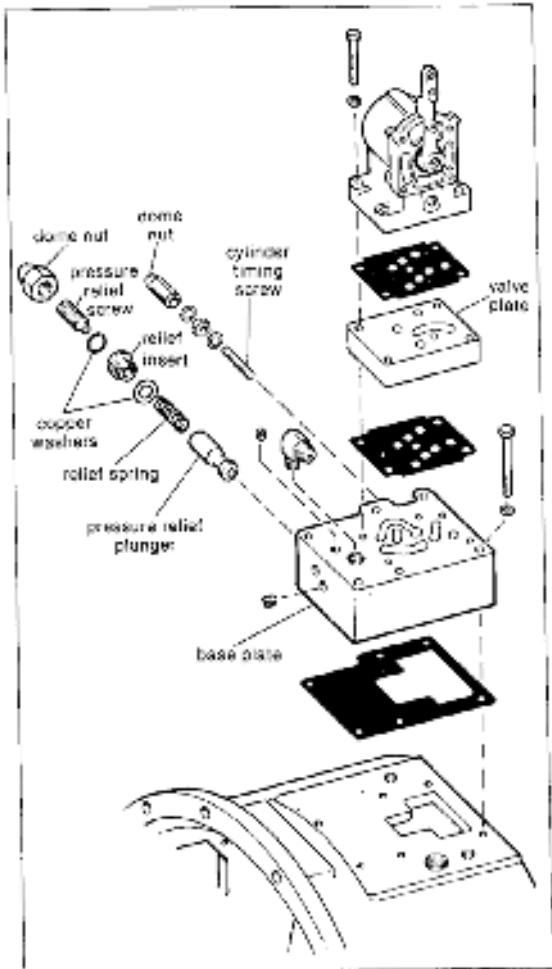

Fig. 21. Exploded View: Selector valve and related parts.

E. PRESSURE RELIEF PLUNGER

1. Remove dome nut, pressure relief screw, relief insert and accompanying washers. See fig. 21. NOTE: REMOVE RELIEF SCREW CAREFULLY BECAUSE RELIEF SPRING IS UNDER TENSION.

2. Check relief plunger to see if it is free moving. If not, inspect plunger for burrs, heat scores, Or distortions. Burrs may be removed with fine Crocus cloth. Otherwise plunger should be Replaced.

3. Clean all parts with a good grade cleaning solvent or diesel fuel. Blow dry with compressed air.

4. Generously lubricate relief plunger with oil or Vaseline. Insert plunger into baseplate. Check Plunger for free movement.

5. Apply washer and install relief insert. Thread pressure relief screw into insert.

6. Cap and lock pressure relief screw with dome nut and washer

REMINDER: Re-establish correct operating Pressure under normal operating speed and Temperature.

SECTION 7. REPAIR OF INTERNAL SUBASSEMBLIES

CAUTION

Avoid contact with rotating output coupling and always shut down engine when doing even minor inspection or repair. Avoid contact with metal surfaces as operating temperatures may exceed 200°F.

7.1 REMOVAL OF REVERSE GEAR

1. Remove drain plug at rear of housing and drain oil from sump.

2. Disconnect all plumbing and wiring and disconnect control linkage.

3. Remove inspection covers and remove oil filter if necessary.

4. Scribe alignment mark across outside diameter of flanges on output coupling or shaft and mating member for exact refit. Disconnect coupling.

5. Remove or push back mating member to obtain maximum clearance and remove pilot ring resting between couplings.

NOTE: Protect mating faces of couplings and pilot ring to insure proper refit and Alignment.

6. Screw two ½"-20 eye bolts into lifting holes on top of housing and connect hoist so it supports the weight of the transmission.

7. Remove capscrews and lockwashers holding housing to oil dam

8. Insert screwdriver or similar object through inspection hole to hold clutch assembly inside forward drum. Slowly move housing aft and away from oil dam.

CAUTION

Clutch must be maintained in forward drum to prevent falling.

9. Remove clutch from forward driving drum.

NOTE: See page 30 for adapter group repair.

Capitol Gasket and Seal Kit No. 1-10195-0000 includes all necessary gaskets, seals and o-rings for repairs on the HY 400 and HP 500 transmission.

Gasket and Seal kit No. 1-10196-0000 is designed for all torque converter (TC) models.

7.2 REPLACEMENT WEAR LIMITS

HY-400

ITEM	NEW MINIMUM	DIMENSIONS MAXIMUM	REPLACEMENT WEAR LIMIT
OUTPUT SHAFT O.D At Forward Commutator	1.7450 in.	1.7455 in.	1.7440 in.
O.D At Rear Commutator	2.9970	2.9977	2.9960
O.D At Rear Bearing	3.1495	3.1500	3.1485
Forward Commutator Bushing I.D	1.7495	1.7505	1.7525
Rear Commutator Bushing I.D	2.999	3.000	3.015
CLUTCH DISC THICKNESS Driving (External teeth)	.150	.160	.140
Driven, Thin (Internal Teeth)	.085	.095	.075
Driven, Thick (Internal Teeth)	.160	.175	.150
CLUTCH PACK THICKNESS Clutch No. 1-00100-6000 Forward Pack (Compressed)	1.645	1.785	1.505
Reverse Pack (Compressed)	1.410	1.530	1.290
CLUTCH PACK THICKNESS Clutch No. 1-00100-4100 Forward Pack (Compressed)	1.645	1.785	1.505
CLUTCH PACK THICKNESS Clutch No. 1-00100-4200 Forward Pack (Compressed)	1.645	1.785	1.505
Brake (Compressed)	.470	.510	.440

HP-500

ITEM	NEW MINIMUM	DIMENSIONS MAXIMUM	REPLACEMENT WEAR LIMIT
OUTPUT SHAFT O.D At Forward Commutator	2.2450 in.	2.2455 in.	2.2440 in.
O.D At Rear Commutator	2.9970	2.9977	2.9960
O.D At Rear Bearing	3.1495	3.1500	3.1485
FORWARD COMMUTATOR BUSHING I.D	2.250	2.251	2.253
REAR COMMUTATOR BUSHING I.D	2.999	3.000	3.015
CLUTCH DISC THICKNESS Driving (External Teeth)	.184	.189	.174
Driven (Internal Teeth)	.085	.095	.075
CLUTCH PACK THICKNESS Clutch No. 1-00100-2419 Forward Pack (Compressed)	2.152	2.272	1.992
Reverse Pack (Compressed)	1.883	1.946	1.743
CLUTCH PACK THICKNESS Clutch No. 1-00100-2420 Forward Pack (Compressed)	2.690	2.840	2.490
Reverse Pack (Compressed)	2.421	2.556	2.241
CLUTCH PACK THICKNESS Clutch No. 1-00100-4300 Forward Pack (Compressed)	2.690	2.840	2.490
Brake (Compressed)	.538	.568	.498
ITEM	REPLACEMENT		

HY-400
& HP-500

	WEAR LIMIT
OIL PUMP (BUSHINGS- See pages 17 and 18)	IF DEEP GROOVES ARE PRESENT, OR MORE THAN .006" CLEARANCE EXISTS BETWEEN PUMP GEARS AND BODY
SELECTOR VALVE	IF DEEP GROOVES ARE PRESENT (.025" DEEP)
DRIVING DRUM SPLINES CLUTCH END FLANGE SPLINES	IF GROOVES ARE PRESENT VERTICAL TO THE SPLINE
ALL SPLINED PARTS	REPLACE IF FIT IS NOT SNUG.

7.3 CLUTCH AND GEAR CARRIER

A) DIASSEMBLY

1. Remove socket head capscrews, lock washers, (and Allen nuts) securing both clutch flanges to bevel gear carrier.
2. Lift off clutch flanges and clutch discs
3. Press and remove bearing and driving gear from both forward and reverse clutch flange
4. Remove locknuts, clutch identification tag and capscrews from outer perimeter of cylinders.
5. Separate and remove cylinders
6. Remove and discard seal rings from bevel gear carrier. (Always replace with new seal rings to avoid internal leaks.)
7. Remove capscrews and locknuts securing pinion shafts in bevel gear carrier and remove bevel pinion shaft with puller.

B) CLEANING AND INSPECTION

1. Inspect bevel pinions for wear, chips, breaks or out of round condition. If there is any damage, we recommend replacing all of them as a set.
2. Check all pinion bearings and washers for distortion or rough operation. If one bearing needs replacement we recommend replacing them as a set.
3. Clean all parts with a good grade cleaning solvent or diesel fuel. Blow-dry with compressed air.
4. Inspect all oil passages in bevel gear carrier to see that they are free from obstruction.
5. Inspect bevel gear carrier for cracks, chips or worn mounting surfaces. Pay special attention to seal ring grooves. Discard carrier if damaged.
6. Inspect forward commutator bushing for chips, heat scores, scratches, distortion or wear (see Wear limits, p.22). Repair or replace as necessary.

7. Inspect all hardware and springs for wear or distortion (See wear limits p.22) Repair or replace as necessary.

8. Remove clutch discs from flanges and inspect discs for broken teeth, heat scores or wear (See wear limits, page 22). Replace as necessary.

9. Inspect driving gear, and driven gear, for wear, chips or cracks. If either one is damaged we recommend replacing both as a set.

10. Check both clutch flange ball bearings for wear, distortion, or rough operation. Again we recommend replacement of both bearings if either one shows wear.

11. Inspect forward and reverse clutch end flanges for wear, cracks or distortion and make certain all oil passages are free from obstructions.

12. Inspect both clutch cylinders for cracks, distortions or scratches. Repair or replace as necessary.

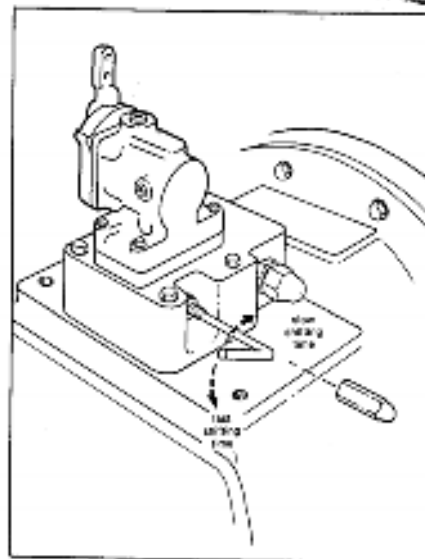

Fig. 22. Clutch Cylinder Timing Adjustment; used to regulate shifting time.

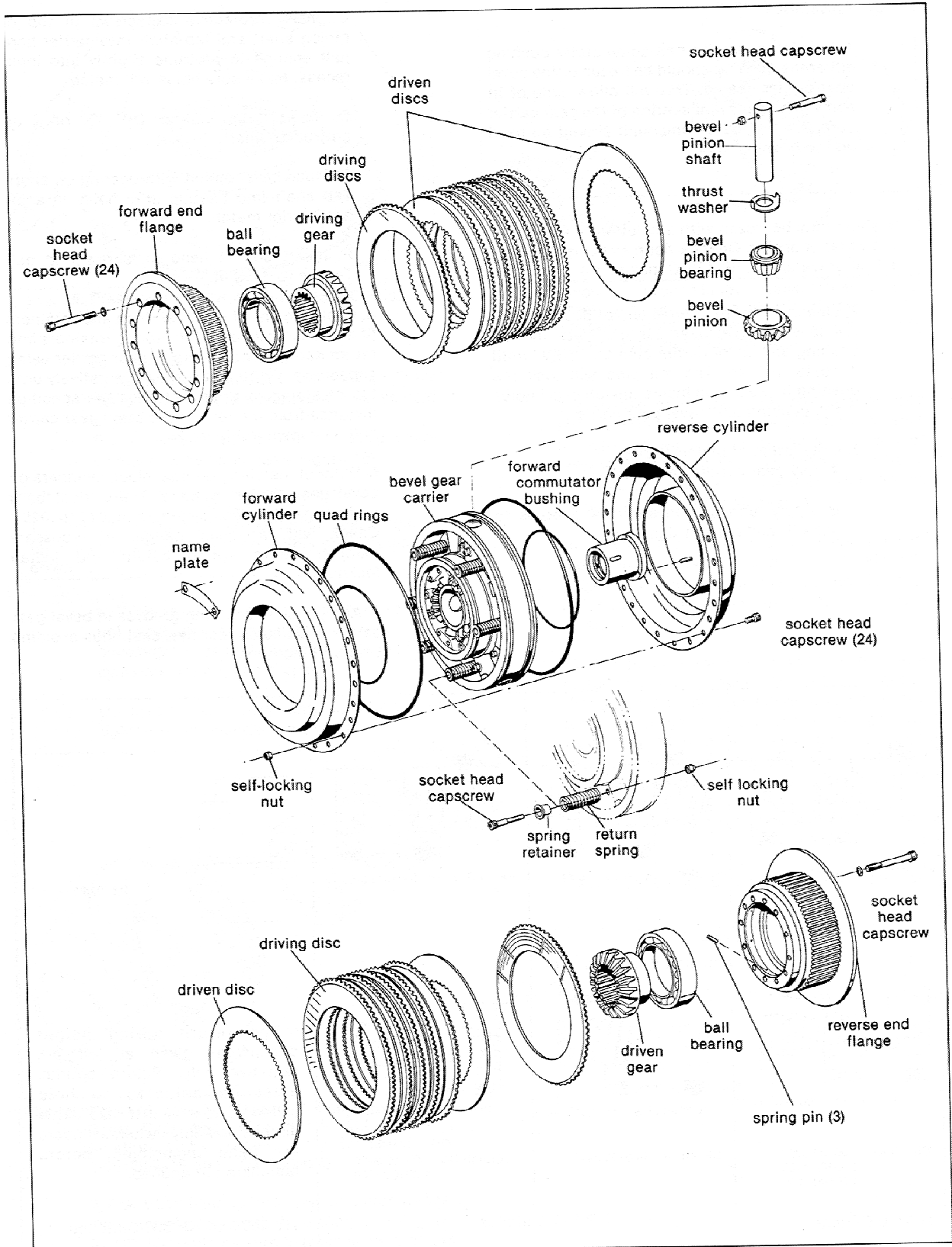

Fig. 23. Clutch and Gear Carrier (HY-400 Clutch No. 1-00100-6000 Shown)

C) ASSEMBLY

1. In order to install a new commutator bushing either the bushing should be frozen or the bevel gear carrier heated. This will allow ease of fit and will help prevent scoring of the gear carrier bore. An anti-seize compound should be used on the bushing also.

NOTE:
Bushing may be frozen with a solution of alcohol and water or dry ice, Gear carrier may be heated in Hot oil or water (275°F, 135°C maximum).

2. Line up holes in flanged end of bushing with roll pins in bevel gear carrier. Press in new bushing on side of carrier stamped 'REV'. Until it seats in bore. The roll pins will lock the bushing in place and insure line-up of oil holes in the bushing and bevel gear carrier.

3. Installation of pinion shafts:

A. Lay gear carrier flat on table

B. Apply lubricant on shafts and bores to Ease fit and prevent damage.

C. Insert protective capscrews in top of Pinion shaft and tap shaft into carrier bore Just enough to protrude slightly into inner recess; Make sure holes will match.

D. Insert thrust washer (HY 400 lonely) on protruding shaft

E. Place bevel pinion with bearing on shaft. Tap shaft into bearing until holes in shaft and carrier match.

F. Insert socket head cap screw and nut. Torque to 8 lbs-ft.

4. Replacement of return springs and retainers (if necessary): insert return spring retainers into return springs and secure in gear carrier using capscrews. Tighten capscrews tentatively until top of spring retainer protrudes the specified distance from the face of the bevel gear carrier hub as shown in figure 24.

5. Without installing o-rings, place cylinders on bevel gear carrier by hand there must be a uniform gap between cylinders of .015 to .025". Check with a feeler gauge. If necessary readjust return spring height and install locknuts.

6. Apply lube in seal ring grooves in bevel gear carrier and slip on four new seal rings avoiding twists in the ring.

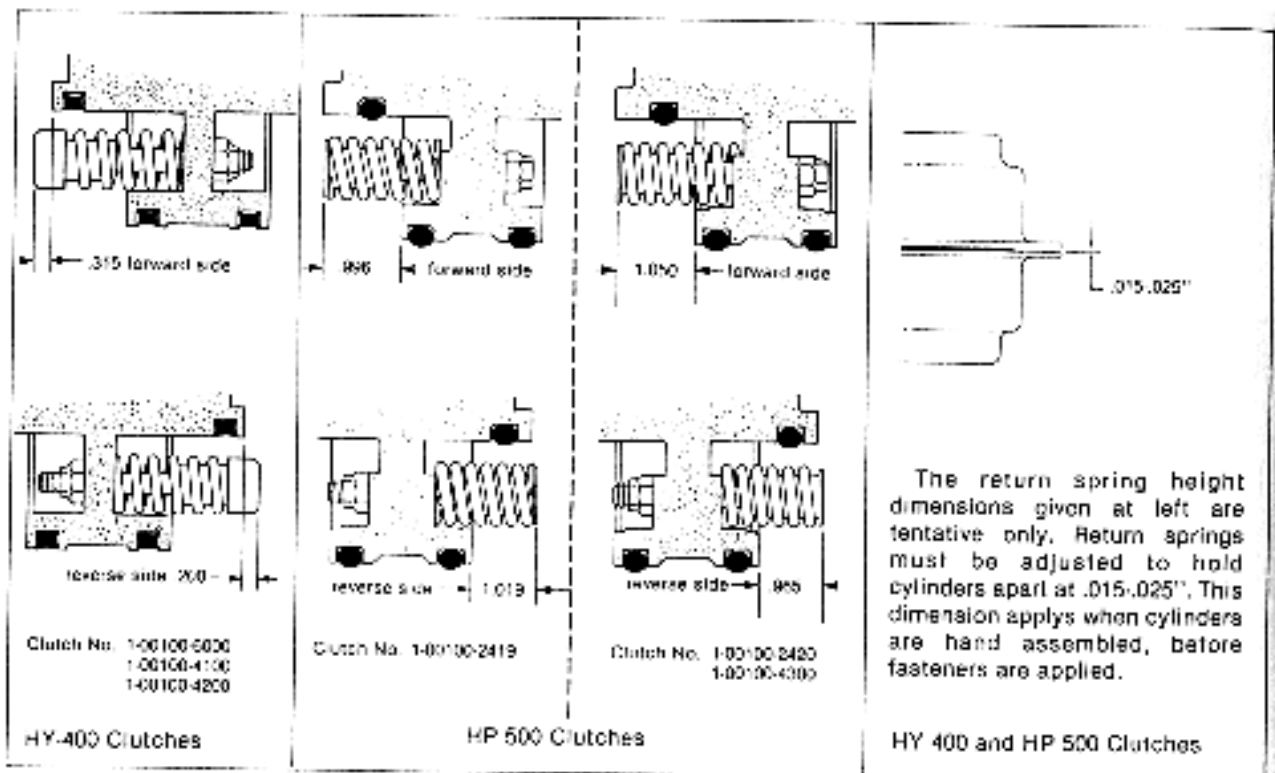

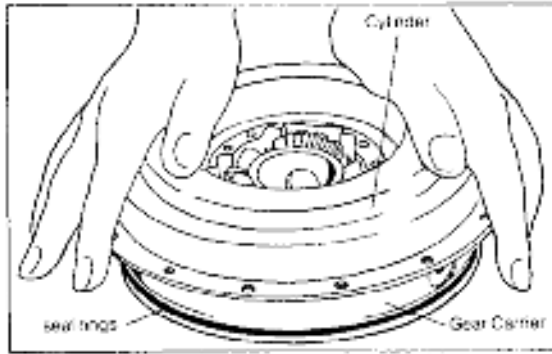

Fig. 25. Pressing Cylinder on Bevel Gear Carrier

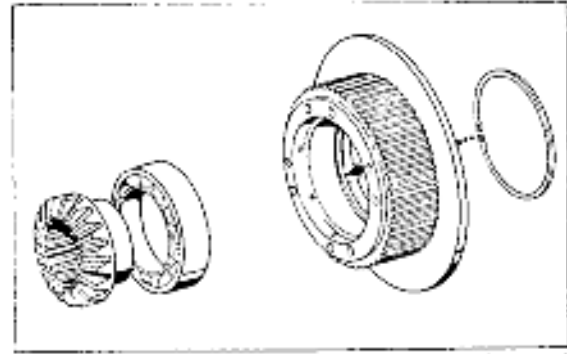

Fig. 27. Reverse Clutch Flange, Roller Bearing and Bevel Gear (snap ring in HP clutches only; location arrow applies only to clutch no. 1-00100-2419 and 1-00100-2420).

7. To install cylinders:

- A. Apply a light coat of lubricant on inner walls of each clutch cylinder as well as seal rings/
- B. With forward side of gear carrier up, press cylinder on by hand (see fig. 25)

CAUTION:

To prevent twisting or damaging of seal rings, take care to slip cylinders on evenly and straight down.

10.

- C. Turn bevel gear carrier over (reverse side up) and press remaining cylinder on, checking to see that cap screw holes in both cylinders are aligned properly.
- D. Insert capscrews and lock nuts and tighten to 15 pounds-foot torque.

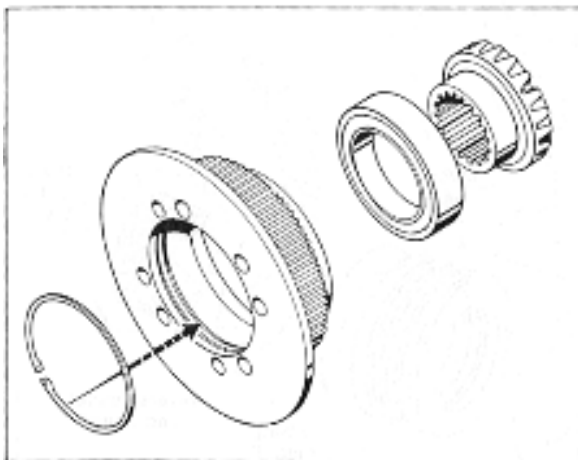

Fig. 26. Forward Clutch Flange, Roller Bearing and Bevel Gear (snap ring in HP clutches only; location arrow applies only to clutch no. 1-00100-2419 and 1-00100-2420).

8. Press ball bearing into forward clutch flange. Press bevel gear into ball bearing. See fig. 26. In "HP" 500 units be sure to replace snap ring in innermost groove forward flange.

9. Likewise press the other ball bearing into reverse clutch flange. On HP 500 clutch be sure to install snap ring in outermost groove of reverse flange (see fig. 27). Then press bevel gear into ball bearing. Check that ball bearings on both flanges are well seated.

10. Arrange the driving friction discs (external tooth) with the steel driven discs (internal tooth) against the forward and reverse clutch flanges. Refer to the appropriate illustration on pages 27 And 28.

11. Position reverse clutch flange and reverse clutch discs on reverse side of gear carrier (flange on commutator bushing is on reverse side). Position forward clutch flange with forward clutch discs and fasten both flanges to gear carrier. Tighten capscrews to 28 foot-pounds torque.

12. Check for free movement of gears in clutch assembly

clutch assembly is now ready for installation.

NOTE:

Clutch cylinder timing adjustment is illustrated on p. 23

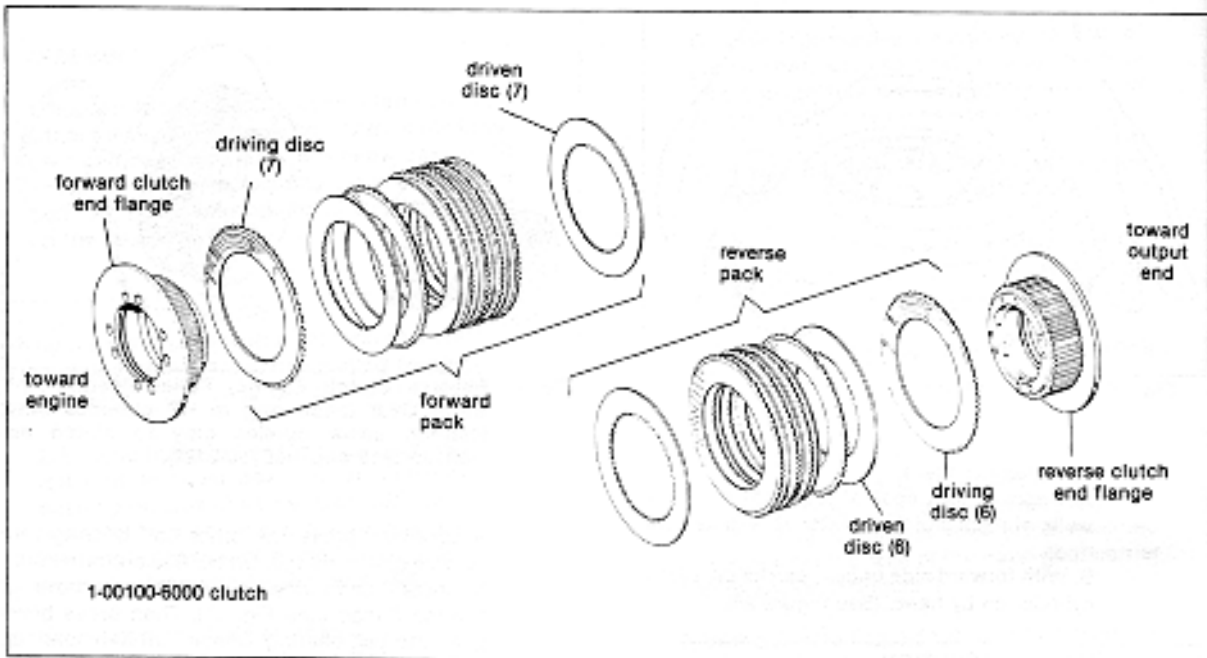

Fig. 28. HY-400 Clutch Disc Configuration (1-00100-6000 Clutch Only)

NOTE: Regarding HY-400 clutches 1-00100-4100 and 1-00100-4200 see parts information section, pages 45 and 47.

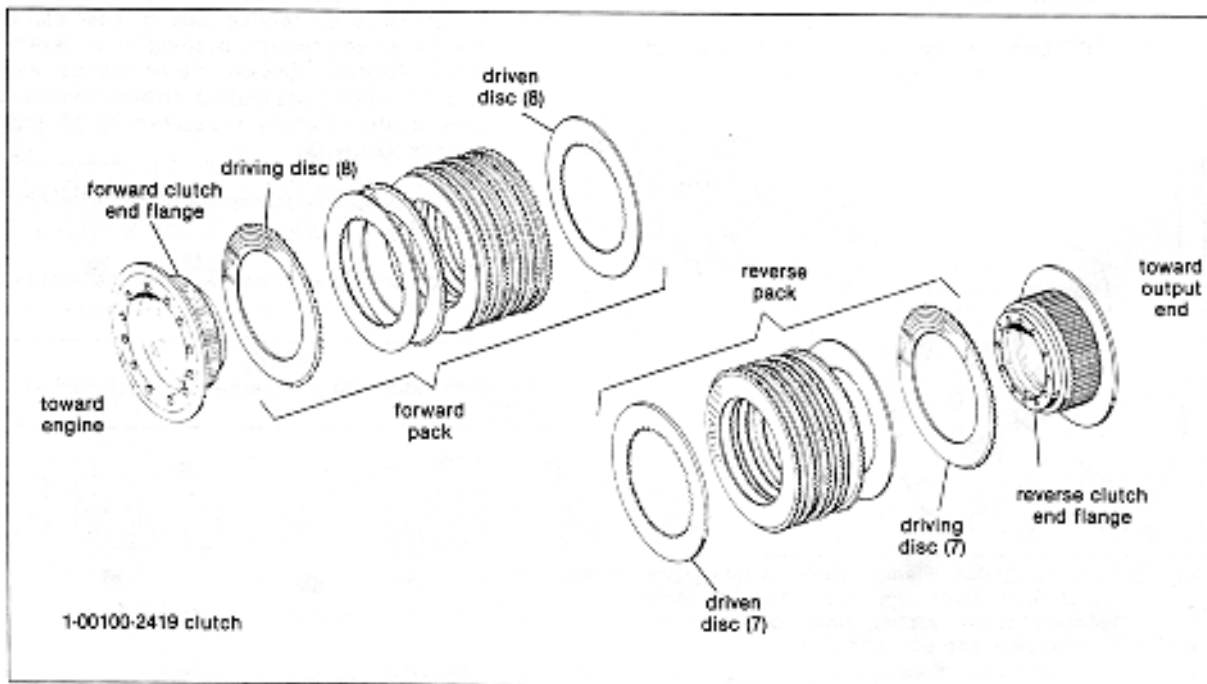

Fig. 29. HY-500 Clutch Disc Configuration (1-00100-2419 Clutch Only)

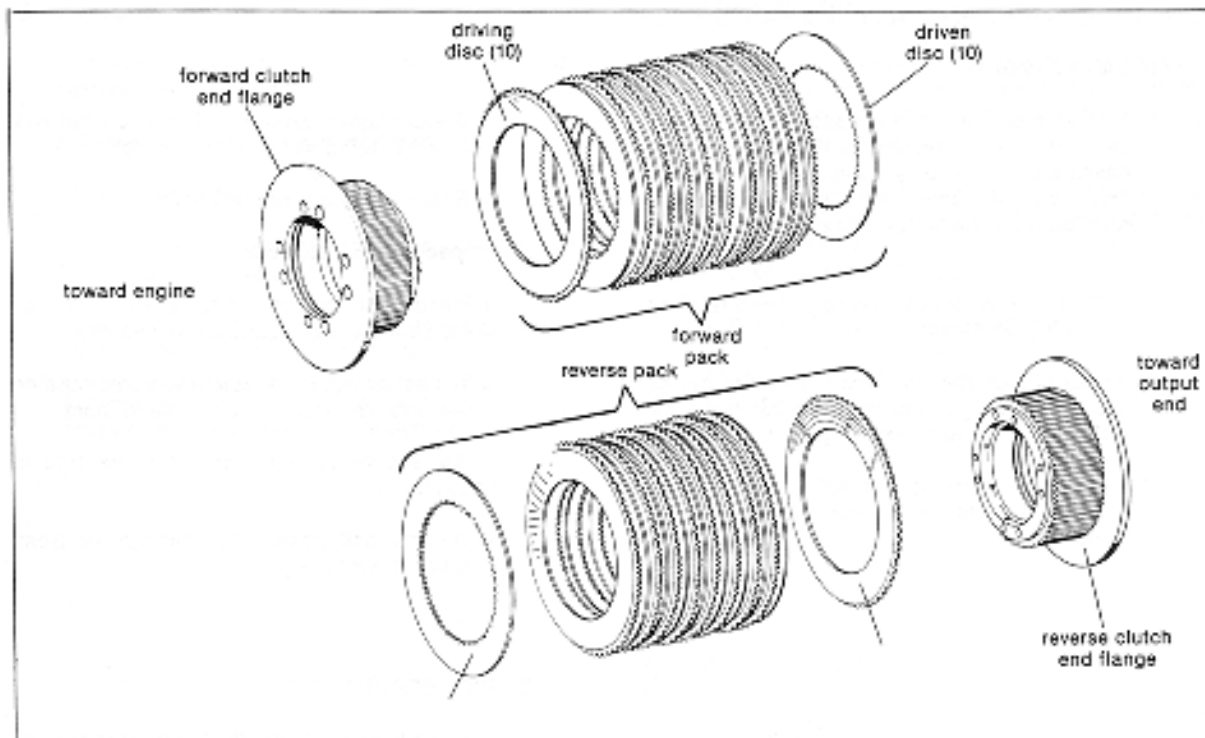

Fig. 30. HP 500 Clutch Disc Configuration (1-00100-2420 Clutch only)

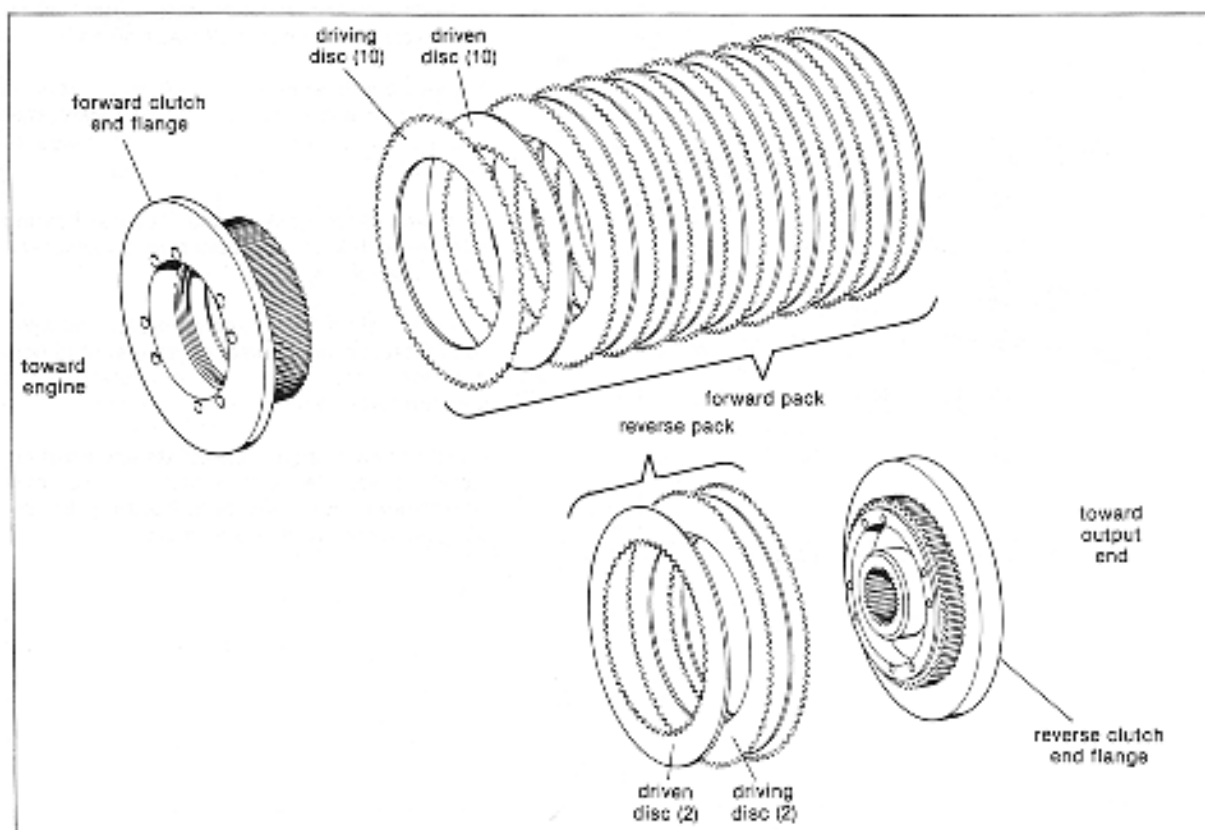

Fig. 31. HP 500 PTO W/Brake Clutch Disc Configuration (1-00100-4300 only)

7.4 OUT PUT SHAFT AND RELATED PARTS

A) DISSASSEMBLY

1. Remove hex head capscrews holding selector valve base plate with selector valve. Lift commutator tubes out of commutator and remove anti-rotation stud. Slide commutator off of output shaft.

2. Remove capscrews holding bearing retainer to bearing container.

3. Tap output shaft with soft hammer out of housing (bearing and bearing retainer will come with shaft.) Discard retainer gasket.

4. Remove bearing locknut with spanner wrench and remove lock washer. See fig. 32 below.

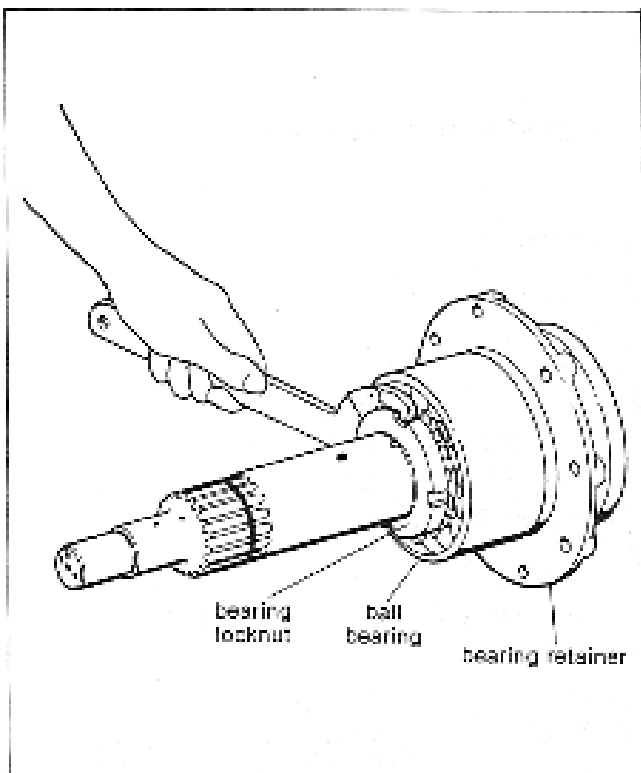

Fig. 32. Removing Bearing Locknut from Shaft.

4

5. Press bearing retainer off of shaft (Oil seal and ball bearing will come with shaft).

6. Remove and discard oil seal

B) INSPECTION AND CLEANING

1. Inspect commutator for damage or wear (See wear limits p.22) Replace if necessary.

2. Inspect O-rings in base plate and commutator. If they are no longer pliable replace them

3. Make sure commutator tubes are free of obstruction.

4. Inspect ball bearing for damage or wear. Replace if necessary

C) REASSEMBLY

1. Press in new oil seal flush with rear surface of bearing retainer.

2. Slide bearing retainer onto output shaft being very careful not to damage oil seal.

3. Press ball bearing onto shaft so it seats on shoulder of shaft. Install bearing lockwasher and tighten bearing locknut. Bend tangs of lockwasher.

4. Install new gasket and secure bearing retainer to bearing container with capscrews and lockwashers.

5. Install new o-rings in commutator and slide commutator in place on shaft so that stud hole is on starboard side. Install commutator tubes and anti-rotation stud.

6. Install new o-ring in baseplate and carefully install baseplate and selector valve over commutator tubes and onto housing. Secure with capscrews and lockwashers.

7.5 HOUSING PARTS

1. Clean oil breather and suction screen and replace filter element.
2. Flush clean and inspect main housing
 - a. Clean sump
 - b. Check front bell end for nicks and burrs. Use a flat file for deburring
3. Inspect reverse clutch drum for grooves or excess wear. Replace if necessary.
4. Inspect surfaces of output flange and mating coupling and file smooth if necessary.

7.6 ADAPTER GROUP

1. Clean and inspect stub shaft (mounted on engine flywheel) and forward clutch driving drum. Inspect spline on stub shaft for chips or wear. Replace as necessary.
2. Remove oil dam and inspect labyrinth oil seal on inside diameter. Repair or replace as necessary (wear or damage to seal indicates misalignment- check further!) (See fig. 33).
3. While oil dam is removed inspect flywheel adapter and drive flange for distortion or rough mounting surfaces. Repair or replace as necessary.

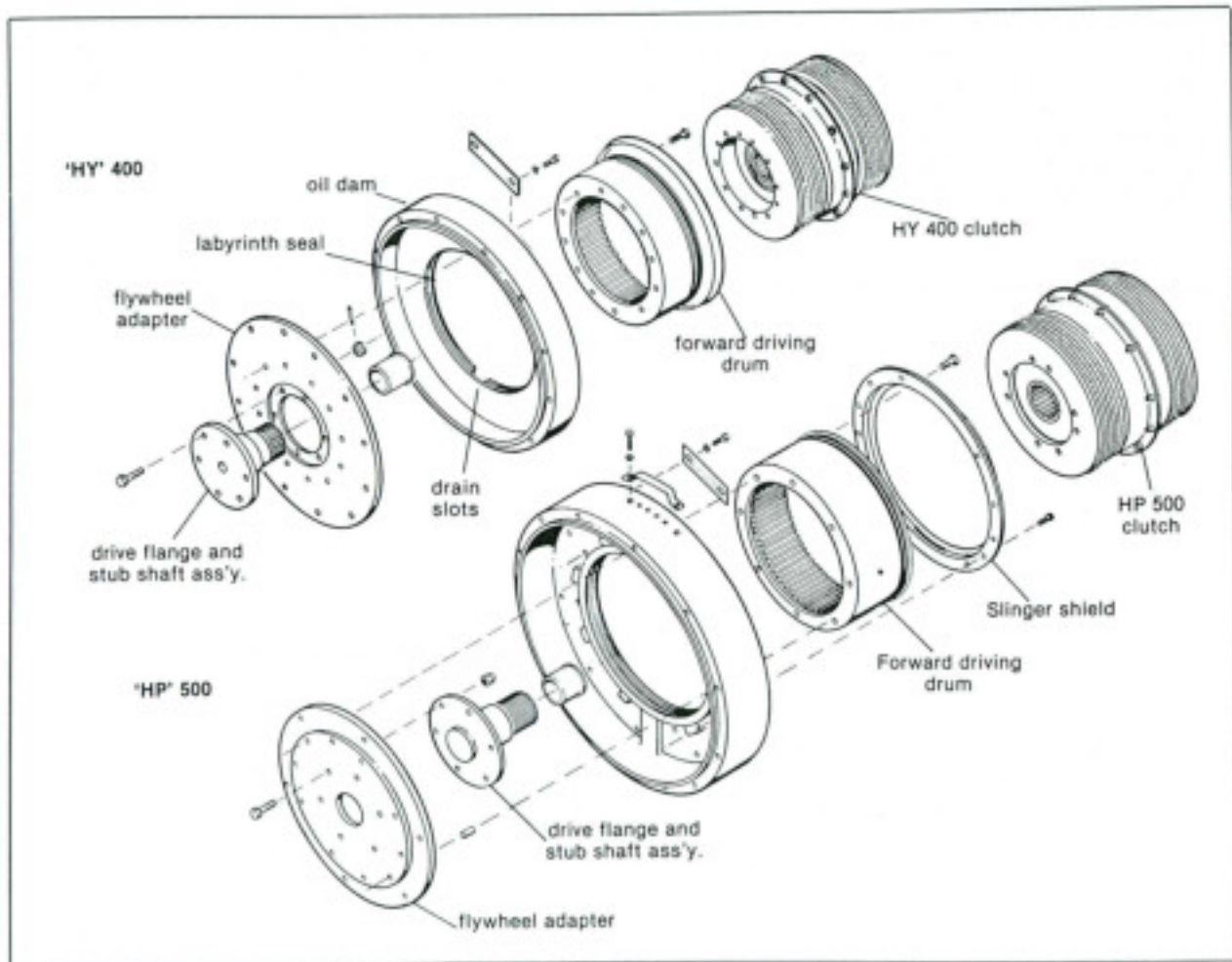

Fig. 33. Adapter Group and Clutch

SECTION 6. REPAIR OF EXTERNAL SUBASSEMBLIES

CAUTION

Avoid contact with rotating output coupling and always shut down engine when doing even minor inspection or repair. Avoid contact with metal surfaces as operating temperatures may exceed 200°F.

Capitol gasket and seal kit NO. 1-10195-0000 includes all necessary gaskets seals and o-rings for repairs on the HY 400 and HP 500 transmissions.

Gasket and seal kit No. 1-10196-0000 is designed for all torque converter (TC) models.

6.1 OIL PUMP

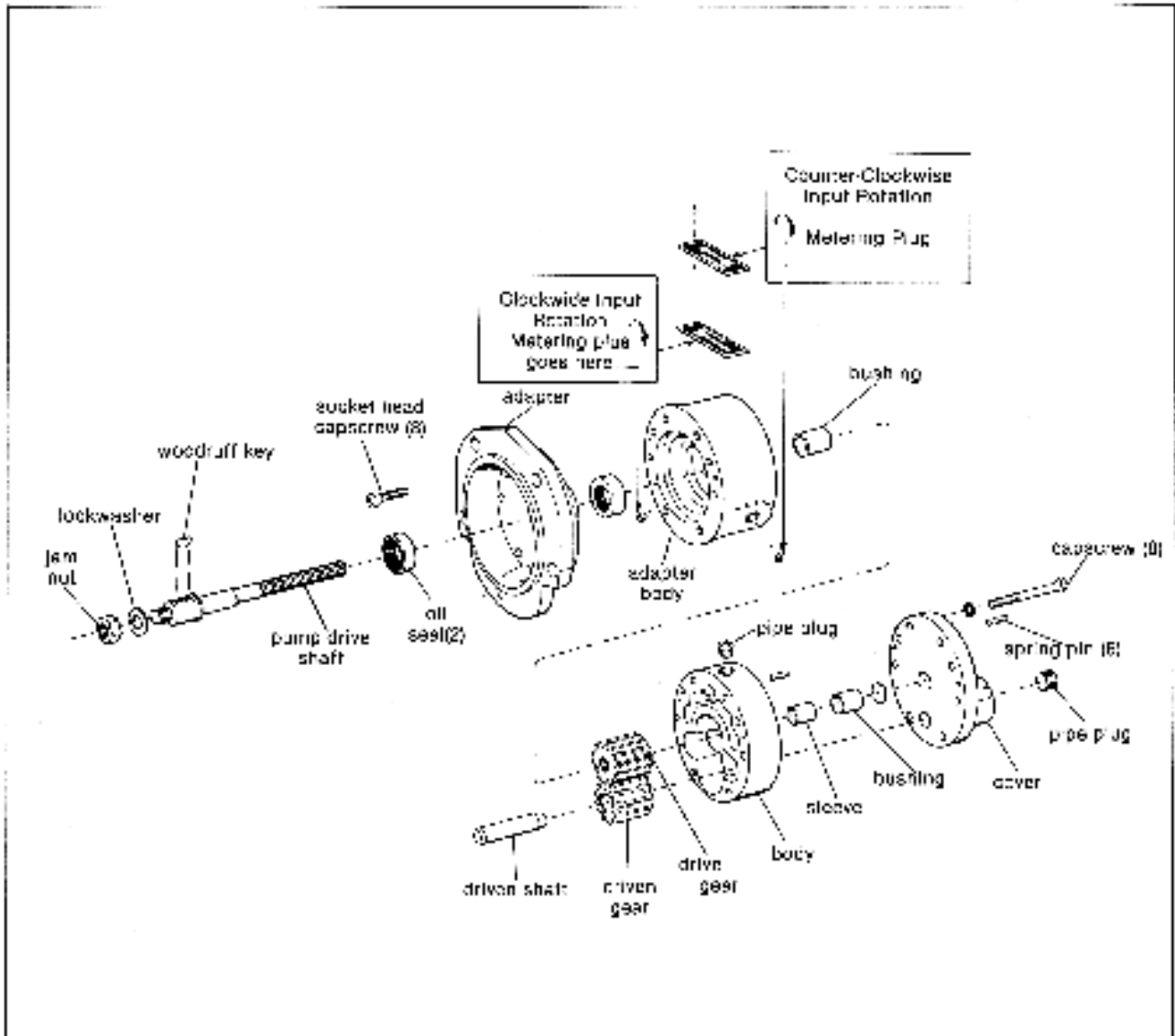

Fig. 1B. Oil Pump; Single Direct Mount Style Shown.

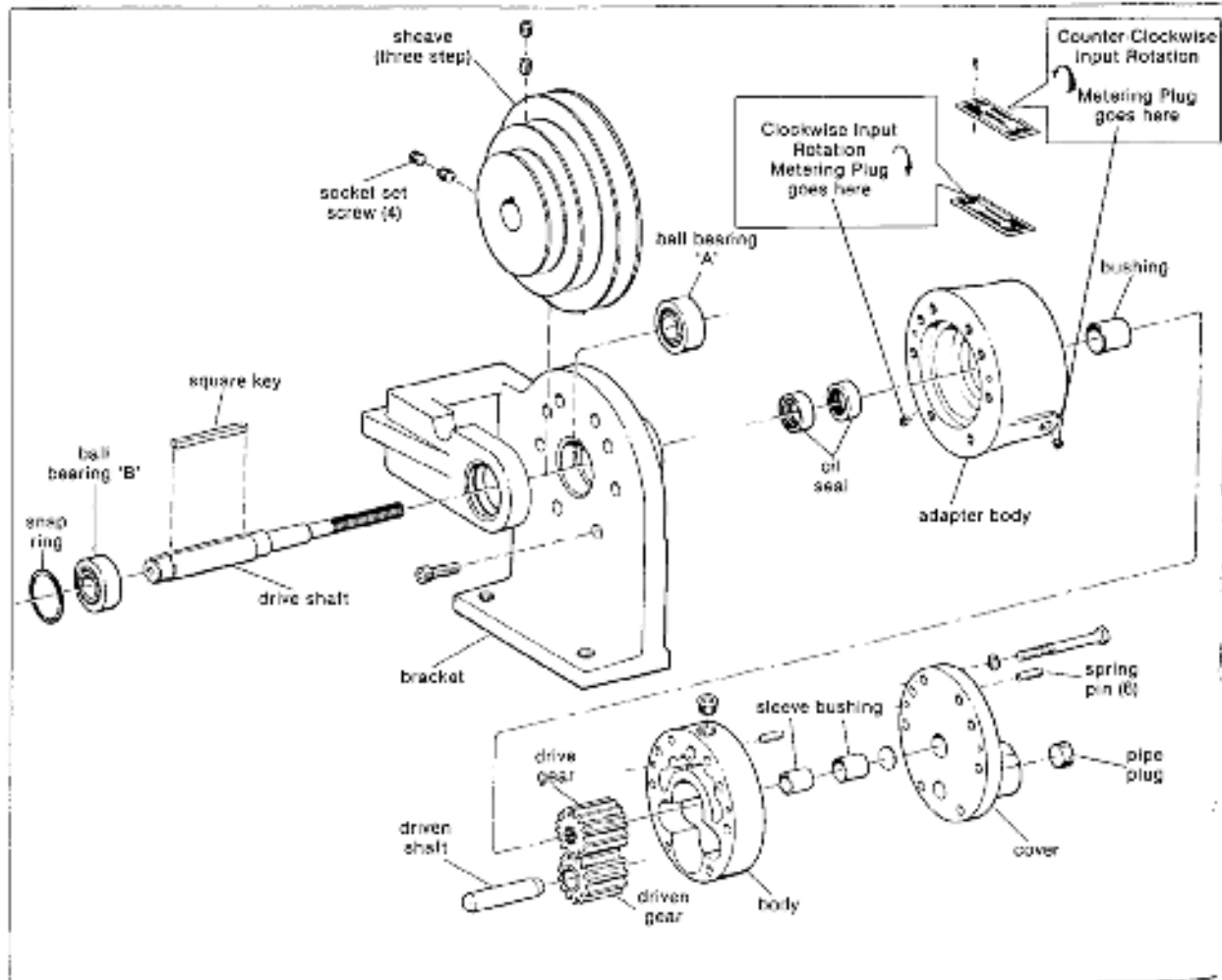

Fig. 19. Oil Pump; Belt Driven Single Style Shown

A. DISASSEMBLY

1. Disconnect hoses and remove mounting bolts securing pump
2. Remove capscrews in cover. Punch mark side of cover, body, and adapter body for reassembly. Separate parts with soft hammer.
3. Belt-driven pumps: remove socket set screws (4) then remove snap ring from bracket. From splined end tap pump shaft out of position With soft hammer.

Direct mounted pumps: Pull shaft through Adapter from keyed end.

4. Remove socket head capscrews (8). Remove and discard oil seals, remove pump gears, and remove driven shaft if wear is suspected. replace them. (New bushing should be reamed to .627/ .628 ID)

B. CLEANING AND INSPECTION

1. Remove all permatex and clean all parts with cleaning solvent or diesel fuel. Blow parts dry with compressed air.
2. Inspect gears and oil pump body for damage or excess wear. See wear limits chart, p. 22.
3. Inspect cover and adapter body for wear caused by gears. If grooving does not exceed .020" surfaces can be ground smooth (.002" maximum cut)
4. Inspect sleeve and bushing in cover for wear, out of round condition or burrs. If they are damaged or if flat discs are worn or loose,

5. Inspect bushing in adapter body. Replace if worn or damaged. New bushing should be reamed to .502/ .503 ID after being pressed in bore.
6. Inspect bushings in driven gear. Replace if necessary and ream new bushings to .627/ .628 ID.
7. Inspect all mating surfaces for smoothness.
8. Check each oil passage and the metered plug for obstruction.

C. RE-ASSEMBLY

Belt-Driven Pumps:

1. Install new oil seals (Metal face inward) In bracket.
2. Install ball bearing 'A' (see fig. 19)
3. Install driven shaft in adapter body (7/16" into bore).
4. Apply very thin * coat of permatex 'super 300' or equivalent to mounting faces and following punch marks place adapter body with bushing installed on bracket. Secure with socket head capscrews (8).
5. Hold sheave and drive belt in position in bracket and with keyway aligned slide drive shaft and key into place, splined end first. Install socket set screws (4) in sheave.
6. Tall ball bearing 'B' (see fig. 10) into bracket and secure with snap ring.
7. Generously lubricate pump gears with Vaseline, lubriplate, or engine weight oil. Slide driving gear onto pump drive shaft and driven gear onto driven shaft (in adapter body).
8. Apply a very thin *coat of permatex 'super 300' sealant or equivalent to mating surfaces and slide body over gears and onto adapter body following punch marks
9. Apply thin * coat of sealant and install cover following punch marks. Loose insert hex head capscrews. Install spring pins (6) flush with cover. Torque capscrews (8) to 16 lbs-ft.

Direct engine mounted pumps:

1. Install new oil seals in adapter (Metal face inward)
2. Install driven shaft in adapter body (7/16" into adapter bore.)
3. Apply a very thin *coat of permatex 'super 300' sealant to mating surfaces and secure adapter body (bushing installed) to adapter following punch marks. Torque socket head capscrews to 16 lbs-ft.
4. Install shaft in adapter spline end first
5. Lubricate pump gears with Vaseline, lubriplate or equivalent. Slide driving gear onto driving shaft and driven gear (bushings installed) following punch marks.
6. Apply thin coat * of 'super 300' permatex to mating surfaces and slide body over gears and onto adapter body, aligning punch marks.
7. Apply a thin coat * of sealant and install cover (bushing, disc and sleeve installed) following punch marks. Loose insert hex head capscrews. Install spring pins (6) flush with cover. Tighten capscrews to 16 lbs-ft torque.

***NOTE:**
Too much sealant can cause pump to malfunction and damage to reverse gear may result.

D. PUMP ROTATION

Input rotation to the pump must be the same as the rotation arrow on the pump itself indicates. If input rotation is changed the pump must change also. The metering plug must be moved to the opposite side and hoses must be reversed. The rotation arrow on the pump should be Changed also. (See page 9 for details)

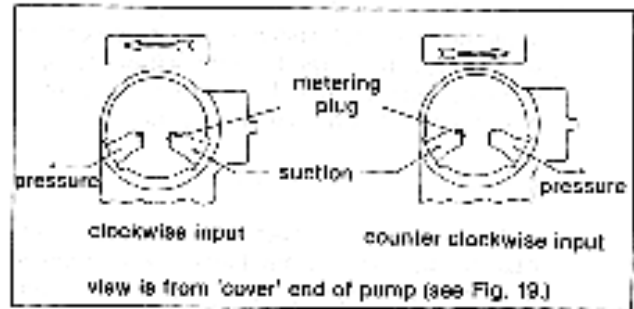

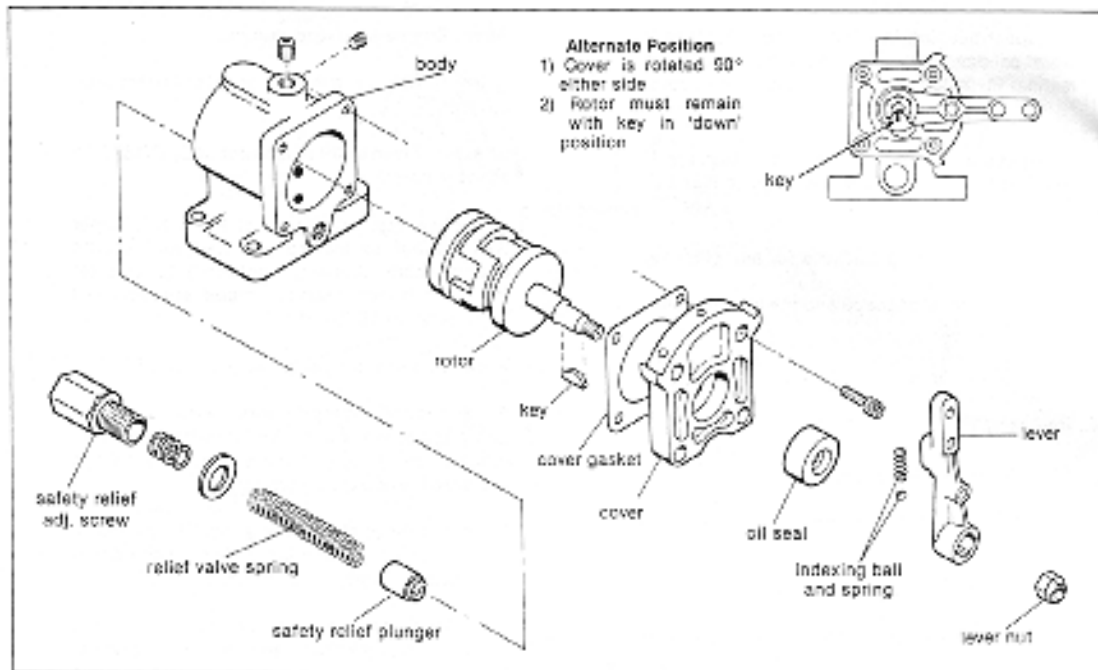

Fig. 20. Selector Valve Assembly

A. REMOVAL

1. Disconnect hoses and control linkage from lever on selector valve.
2. Remove capscrews and lock washers and lift off selector valve and base plate being very careful to keep gaskets in proper configuration for replacement. (they may be fixed in position with wire, etc.)

B. DISASSEMBLY

1. Remove lock nut from rotor and note position of keyways on lever to rotor. (Match mark if desired). Remove lever from rotor being careful not to lose indexing ball and spring.
2. Remove key from rotor shaft
3. (Note position of cover). Remove cover, cover gasket, and rotor from block. (Note relative position of keyway to rotor and lever, Matchmark if desired.)
4. Remove safety relief adjustment screw, washers, spring and plunger. NOTE: SPRING IS UNDER TENSION.

C. CLEANING AND INSPECTION

1. Clean all parts thoroughly with oil and clean all oil ports. Blow dry with compressed air.
2. Inspect rotor and valve block for scoring. Excessive scoring indicates replacement. Valves are not repairable.
3. Inspect oil seal in cover. If it is worn or shows evidence of leaking replace it.

D. ASSEMBLY

NOTE:

On all fittings use permatex 'super 300' sealant, graphite paste, or equivalent. **CAUTION:** do not use No. 1 Permatex or Teflon tape.

1. If necessary install new seal in cover. Press seal in until it bottoms in bore (rubber face out). Apply lubricant to seal
2. Insert rotor shaft through oil seal in cover.
3. Set key in rotor shaft and install lever with indexing ball and spring. Make sure that keyway in rotor shaft remains toward bottom of cover.
4. Tap control lever in position with a soft hammer and secure with lock nut.

5. Position new cover gasket on pilot face of cover.
6. Install rotor with cover into selector valve body. Secure cover with four capscrews. Tighten to 4 pounds-foot torque.
7. Install safety relief adjustment parts in rear of valve body
8. Check for correct assembly by moving lever back and forth. Selector valve is now ready to be installed on main housing. See fig. 21

E. PRESSURE RELIEF PLUNGER

1. Remove dome nut, pressure relief screw, relief insert and accompanying washers. See fig. 21. **NOTE: REMOVE RELIEF SCREW CAREFULLY BECAUSE RELIEF SPRING IS UNDER TENSION.**

2. Check relief plunger to see if it is free moving. If not, inspect plunger for burrs, heat scores, Or distortions. Burrs may be removed with fine Crocus clothe. Otherwise plunger should be Replaced.

3. Clean all parts with a good grade cleaning solvent or diesel fuel. Blowdry with compressed air.

4. Generously lubricate relief plunger with oil or Vaseline. Insert plunger into baseplate. Check Plunger for free movement.

5. Apply washer and install relief insert. Thread pressure relief screw into insert.

6. Cap and lock pressure relief screw with dome nut and washer

REMINDER: Re-establish correct operating Pressure under normal operating speed and Temperature.

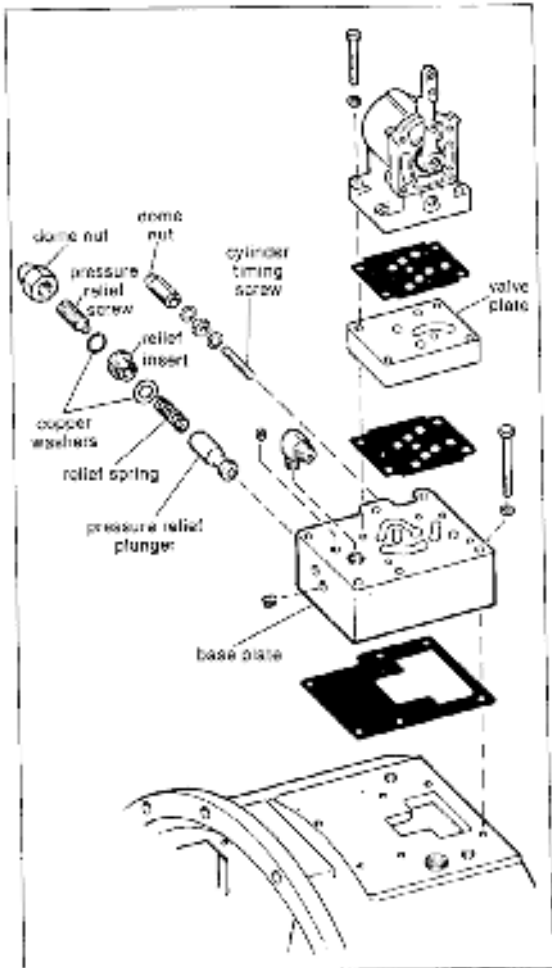

Fig. 21. Exploded View: Selector valve and related parts.

SECTION 7. REPAIR OF INTERNAL SUBASSEMBLIES

CAUTION

Avoid contact with rotating output coupling and always shut down engine when doing even minor inspection or repair. Avoid contact with metal surfaces as operating temperatures may exceed 200°F.

7.1 REMOVAL OF REVERSE GEAR

1. Remove drain plug at rear of housing and drain oil from sump.
2. Disconnect all plumbing and wiring and disconnect control linkage.
3. Remove inspection covers and remove oil filter if necessary.
4. Scribe alignment mark across outside diameter of flanges on output coupling or shaft and mating member for exact refit. Disconnect coupling.
5. Remove or push back mating member to obtain maximum clearance and remove pilot ring resting between couplings.
NOTE: Protect mating faces of couplings and pilot ring to insure proper refit and alignment.
6. Screw two ½"-20 eye bolts into lifting holes on top of housing and connect hoist so it supports the weight of the transmission.
7. Remove capscrews and lockwashers holding housing to oil dam

8. Insert screwdriver or similar object through inspection hole to hold clutch assembly inside forward drum. Slowly move housing aft and away from oil dam.

CAUTION

Clutch must be maintained in forward drum to prevent falling.

9. Remove clutch from forward driving drum.

NOTE: See page 30 for adapter group repair.

Capitol Gasket and Seal Kit No. 1-10195-0000 includes all necessary gaskets, seals and o-rings for repairs on the HY 400 and HP 500 transmission.

Gasket and Seal kit No. 1-10196-0000 is designed for all torque converter (TC) models.

7.2 REPLACEMENT WEAR LIMITS

HY- 400

ITEM	NEW MINIMUM	DIMENSIONS MAXIMUM	REPLACEMENT WEAR LIMIT
OUTPUT SHAFT O.D At Forward Commutator O.D At Rear Commutator O.D At Rear Bearing	1.7450 in. 2.9970 3.1495	1.7455 in. 2.9977 3.1500	1.7440 in. 2.9960 3.1485
Forward Commutator Bushing I.D	1.7495	1.7505	1.7525
Rear Commutator Bushing I.D	2.999	3.000	3.015
CLUTCH DISC THICKNESS Driving (External teeth) Driven, Thin (Internal Teeth) Driven, Thick (Internal Teeth)	.150 .085 .160	.160 .095 .175	.140 .075 .150
CLUTCH PACK THICKNESS Clutch No. 1-00100-6000 Forward Pack (Compressed) Reverse Pack (Compressed)	1.645 1.410	1.785 1.530	1.505 1.290
CLUTCH PACK THICKNESS Clutch No. 1-00100-4100 Forward Pack (Compressed)	1.645	1.785	1.505
CLUTCH PACK THICKNESS Clutch No. 1-00100-4200 Forward Pack (Compressed) Brake (Compressed)	1.645 .470	1.785 .510	1.505 .440

HP-500

ITEM	NEW MINIMUM	DIMENSIONS MAXIMUM	REPLACEMENT WEAR LIMIT
OUTPUT SHAFT O.D At Forward Commutator O.D At Rear Commutator O.D At Rear Bearing	2.2450 in. 2.9970 3.1495	2.2455 in. 2.9977 3.1500	2.2440 in. 2.9960 3.1485
FORWARD COMMUTATOR BUSHING I.D	2.250	2.251	2.253
REAR COMMUTATOR BUSHING I.D	2.999	3.000	3.015
CLUTCH DISC THICKNESS Driving (External Teeth) Driven (Internal Teeth)	.184 .085	.189 .095	.174 .075
CLUTCH PACK THICKNESS Clutch No. 1-00100-2419 Forward Pack (Compressed) Reverse Pack (Compressed)	2.152 1.883	2.272 1.946	1.992 1.743
CLUTCH PACK THICKNESS Clutch No. 1-00100-2420 Forward Pack (Compressed) Reverse Pack (Compressed)	2.690 2.421	2.840 2.556	2.490 2.241
CLUTCH PACK THICKNESS Clutch No. 1-00100-4300			

HY-400
& HP-500

Forward Pack (Compressed)	2.690	2.840	2.490
Brake (Compressed)	.538	.568	.498
ITEM	REPLACEMENT WEAR LIMIT		
OIL PUMP (BUSHINGS- See pages 17 and 18)	IF DEEP GROOVES ARE PRESENT, OR MORE THAN .006" CLEARANCE EXISTS BETWEEN PUMP GEARS AND BODY		
SELECTOR VALVE	IF DEEP GROOVES ARE PRESENT (.025" DEEP)		
DRIVING DRUM SPLINES CLUTCH END FLANGE SPLINES	IF GROOVES ARE PRESENT VERTICAL TO THE SPLINE		
ALL SPLINED PARTS	REPLACE IF FIT IS NOT SNUG.		

7.3 CLUTCH AND GEAR CARRIER

A) DIASSEMBLY

1. Remove socket head capscrews, lock washers, (and Allen nuts) securing both clutch flanges to bevel gear carrier.
2. Lift off clutch flanges and clutch discs
3. Press and remove bearing and driving gear from both forward and reverse clutch flange
4. Remove locknuts, clutch identification tag and capscrews from outer perimeter of cylinders.
5. Separate and remove cylinders
6. Remove and discard seal rings from bevel gear carrier. (Always replace with new seal rings to avoid internal leaks.)
7. Remove capscrews and locknuts securing pinion shafts in bevel gear carrier and remove bevel pinion shaft with puller.

B) CLEANING AND INSPECTION

1. Inspect bevel pinions for wear, chips, breaks or out of round condition. If there is any damage, we recommend replacing all of them as a set.
2. Check all pinion bearings and washers for distortion or rough operation. If one bearing needs replacement we recommend replacing them as a set.
3. Clean all parts with a good grade cleaning solvent or diesel fuel. Blow-dry with compressed air.
4. Inspect all oil passages in bevel gear carrier to see that they are free from obstruction.
5. Inspect bevel gear carrier for cracks, chips or worn mounting surfaces. Pay special attention to seal ring grooves. Discard carrier if damaged.
6. Inspect forward commutator bushing for chips, heat scores, scratches, distortion or wear (see Wear limits, p.22). Repair or replace as necessary.

7. Inspect all hardware and springs for wear or distortion (See wear limits p.22) Repair or replace as necessary.

8. Remove clutch discs from flanges and inspect discs for broken teeth, heat scores or wear (See wear limits, page 22). Replace as necessary.

9. Inspect driving gear, and driven gear, for wear, chips or cracks. If either one is damaged we recommend replacing both as a set.

10. Check both clutch flange ball bearings for wear, distortion, or rough operation. Again we recommend replacement of both bearings if either one shows wear.

11. Inspect forward and reverse clutch end flanges for wear, cracks or distortion and make certain all oil passages are free from obstructions.

12. Inspect both clutch cylinders for cracks, distortions or scratches. Repair or replace as necessary.

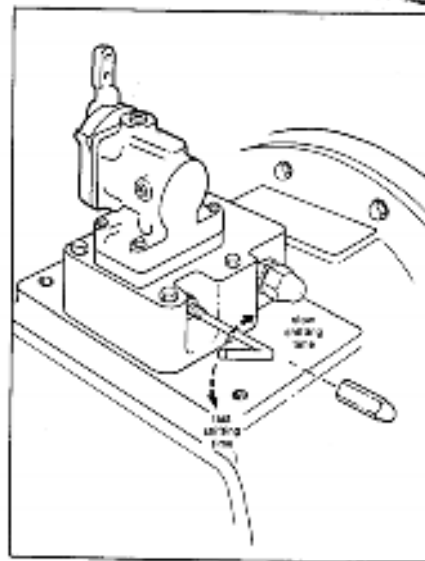

Fig. 22. Clutch Cylinder Timing Adjustment; used to regulate shifting time.

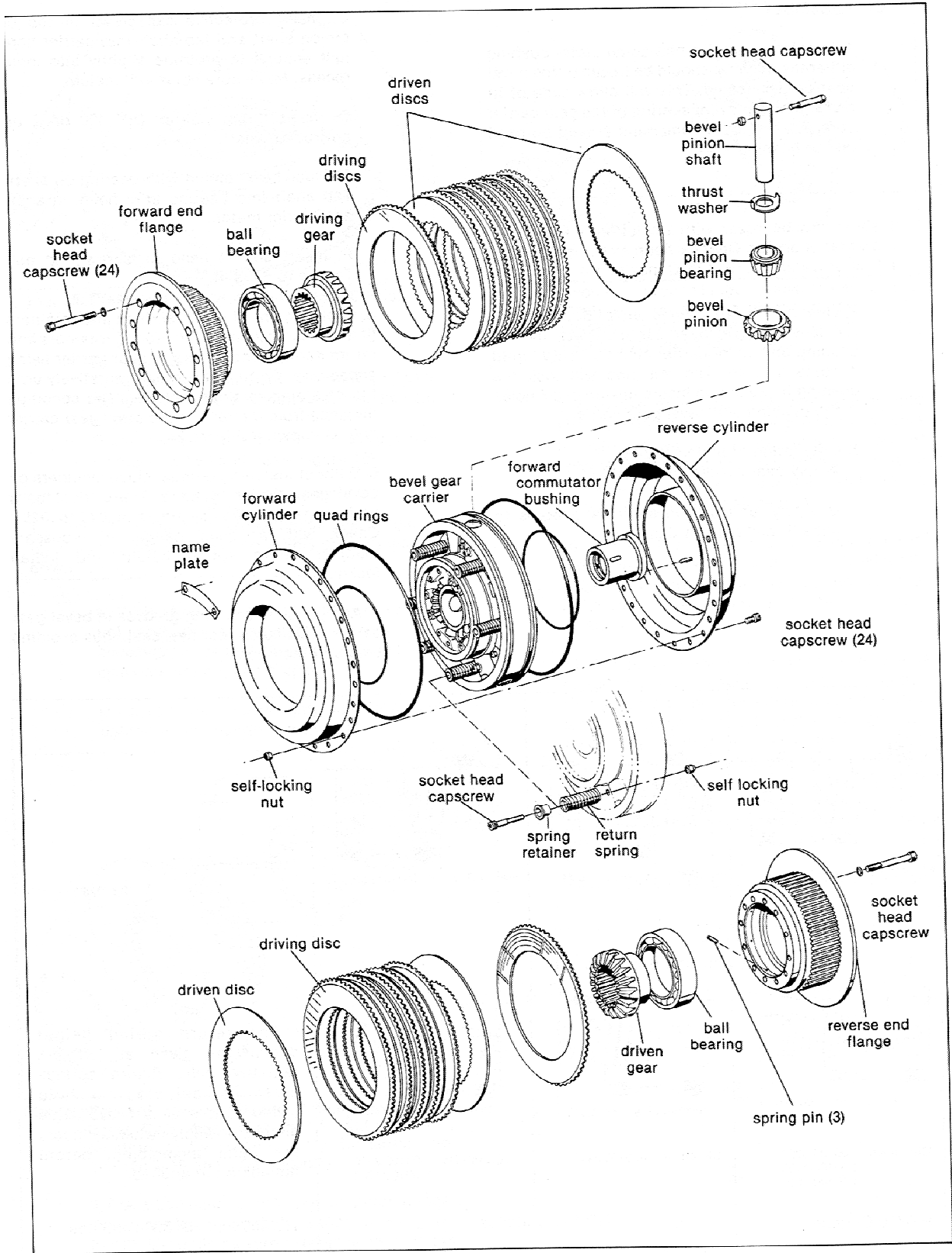

Fig. 23. Clutch and Gear Carrier (HY-400 Clutch No. 1-00100-6000 Shown)

1. In order to install a new commutator bushing either the bushing should be frozen or the bevel gear carrier heated. This will allow ease of fit and will help prevent scoring of the gear carrier bore. An anti-seize compound should be used on the bushing also.

NOTE:
 Bushing may be frozen with a solution of alcohol and water or dry ice, Gear carrier may be heated in Hot oil or water (275°F, 135°C maximum).

2. Line up holes in flanged end of bushing with roll pins in bevel gear carrier. Press in new bushing on side of carrier stamped 'REV'. Until it seats in bore. The roll pins will lock the bushing in place and insure line-up of oil holes in the bushing and bevel gear carrier.

3. Installation of pinion shafts:

A. Lay gear carrier flat on table

B. Apply lubricant on shafts and bores to Ease fit and prevent damage.

C. Insert protective capscrews in top of Pinion shaft and tap shaft into carrier bore Just enough to protrude slightly into inner recess; Make sure holes will match.

D. Insert thrust washer (HY 400 lonely) on protruding shaft

E. Place bevel pinion with bearing on shaft. Tap shaft into bearing until holes in shaft and carrier match.

F. Insert socket head cap screw and nut. Torque to 8 lbs-ft.

4. Replacement of return springs and retainers (if necessary): insert return spring retainers into return springs and secure in gear carrier using capscrews. Tighten capscrews tentatively until top of spring retainer protrudes the specified distance from the face of the bevel gear carrier hub as shown in figure 24.

5. Without installing o-rings, place cylinders on bevel gear carrier by hand there must be a uniform gap between cylinders of .015 to .025". Check with a feeler gauge. If necessary readjust return spring height and install locknuts.

6. Apply lube in seal ring grooves in bevel gear carrier and slip on four new seal rings avoiding twists in the ring.

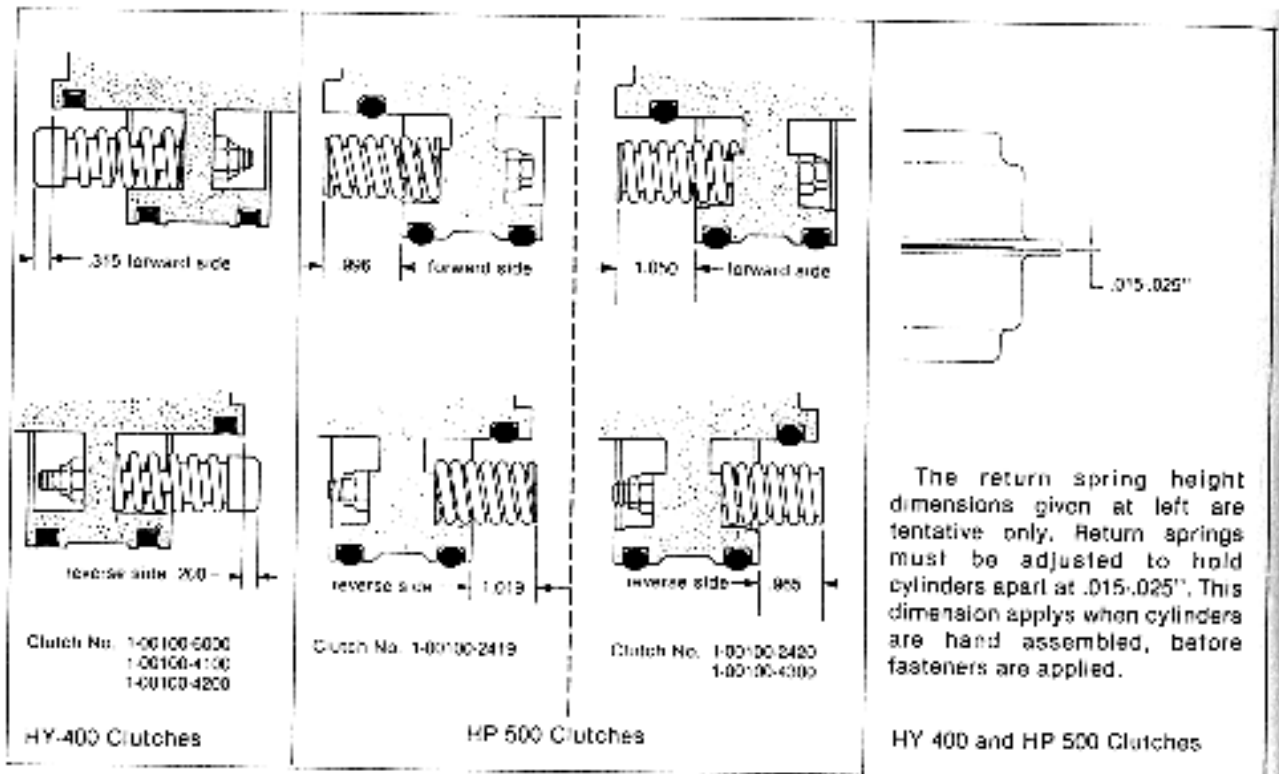

Fig. 24. Clutch Return Spring Height Adjustment

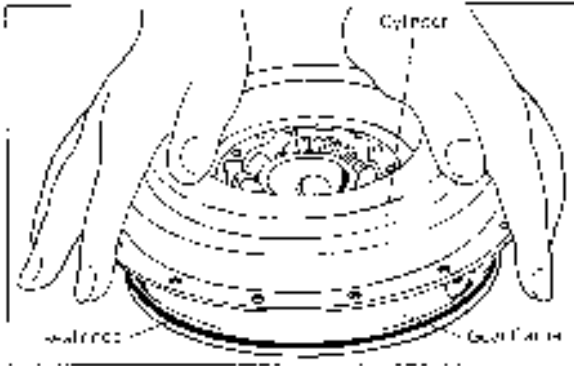

Fig. 25. Pressing Cylinder on Bevel Gear Carrier

7. To install cylinders:

- A. Apply a light coat of lubricant on inner walls of each clutch cylinder as well as seal rings/
- B. With forward side of gear carrier up, press cylinder on by hand (see fig. 25)

CAUTION:
To prevent twisting or damaging of seal rings, take care to slip cylinders on evenly and straight down.

- C. Turn bevel gear carrier over (reverse side up) and press remaining cylinder on, checking to see that cap screw holes in both cylinders are aligned properly.
- D. Insert capscrews and lock nuts and tighten to 15 pounds-foot torque.

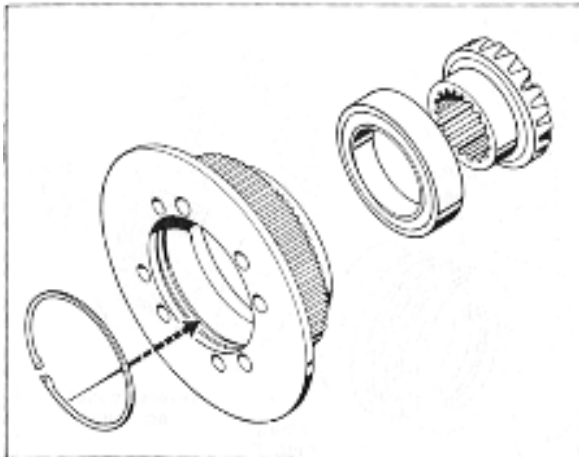

Fig. 26. Forward Clutch Flange, Roller Bearing and Bevel Gear (snap ring in HP clutches only; location arrow applies only to clutch no. 1-00100-2419 and 1-00100-2420).

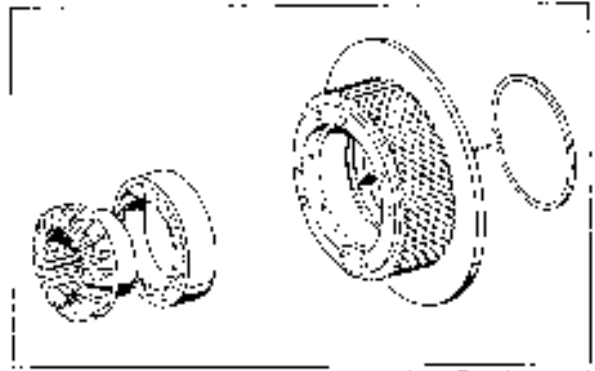

Fig. 27. Reverse Clutch Flange, Roller Bearing and Bevel Gear (snap ring in HP clutches only; location arrow applies only to clutch no. 1-00100-2419 and 1-00100-2420).

8. Press ball bearing into forward clutch flange. Press bevel gear into ball bearing. See fig. 26. In "HP" 500 units be sure to replace snap ring in innermost groove forward flange.

9. Likewise press the other ball bearing into reverse clutch flange. On HP 500 clutch be sure to install snap ring in outermost groove of reverse flange (see fig. 27). Then press bevel gear into ball bearing. Check that ball bearings on both flanges are well seated.

10. Arrange the driving friction discs (external tooth) with the steel driven discs (internal tooth) against the forward and reverse clutch flanges. Refer to the appropriate illustration on pages 27 And 28.

11. Position reverse clutch flange and reverse clutch discs on reverse side of gear carrier (flange on commutator bushing is on reverse side). Position forward clutch flange with forward clutch discs and fasten both flanges to gear carrier. Tighten capscrews to 28 foot-pounds torque.

12. Check for free movement of gears in clutch assembly

clutch assembly is now ready for installation.

NOTE:
Clutch cylinder timing adjustment is illustrated on p. 23

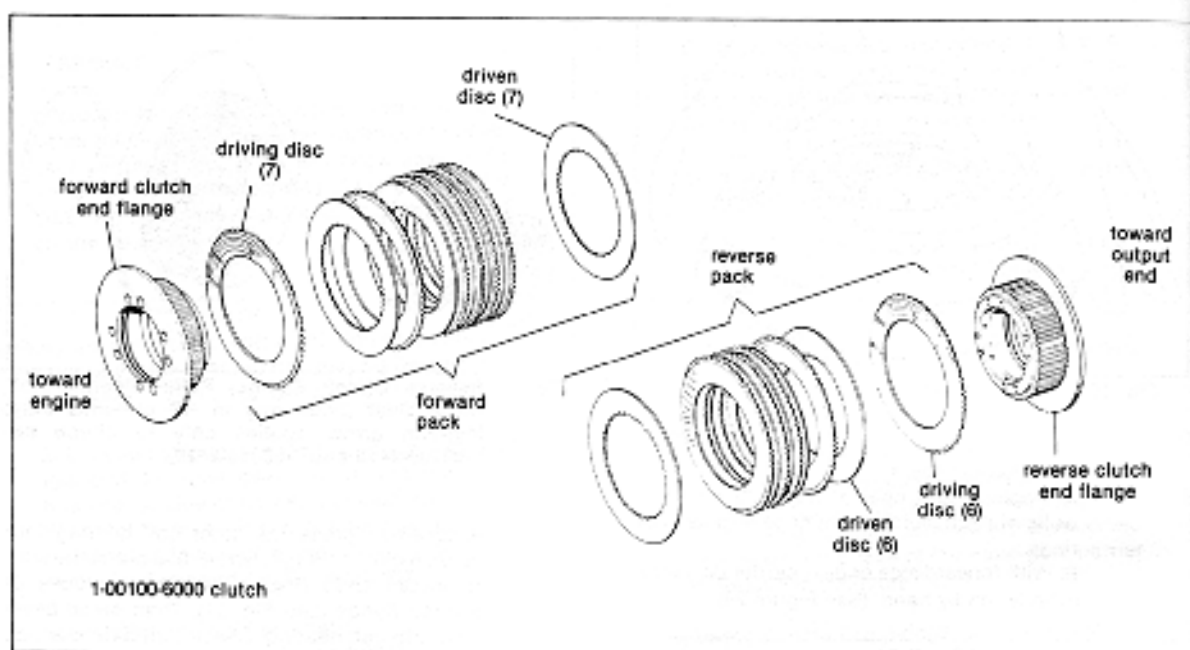

Fig. 28. HY-400 Clutch Disc Configuration (1-00100-6000 Clutch Only)

NOTE: Regarding HY-400 clutches 1-00100-4100 and 1-00100-4200 see parts information section, pages 45 and 47.

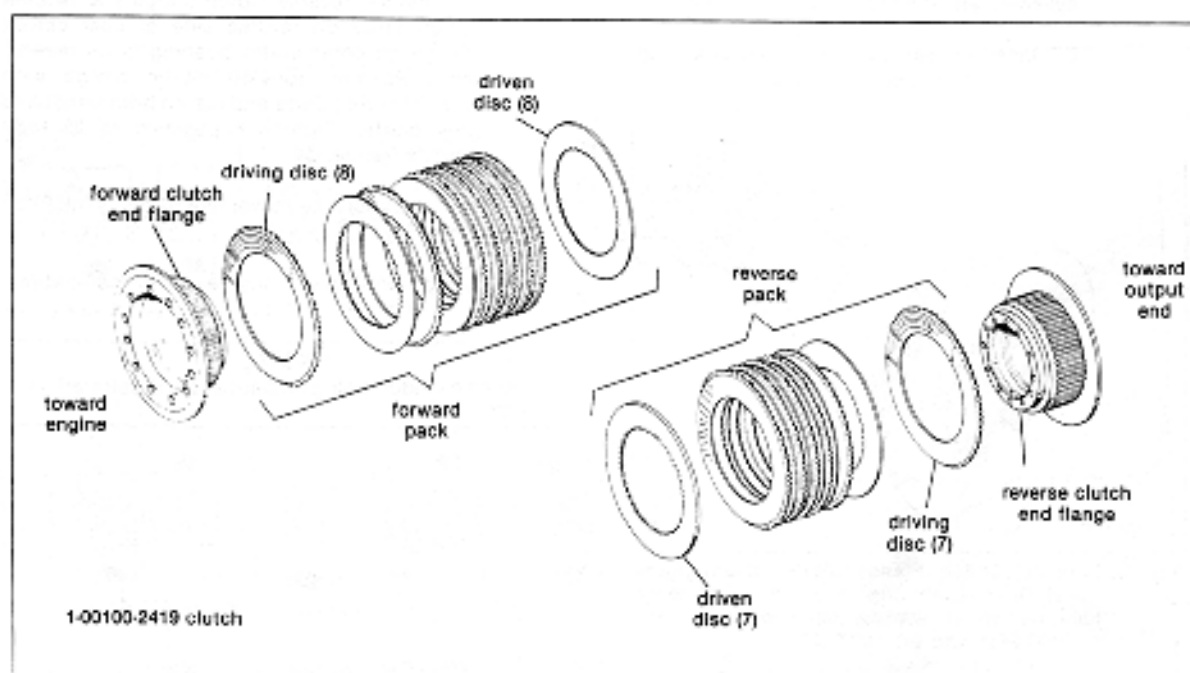

Fig. 29. HY-500 Clutch Disc Configuration (1-00100-2419 Clutch Only)

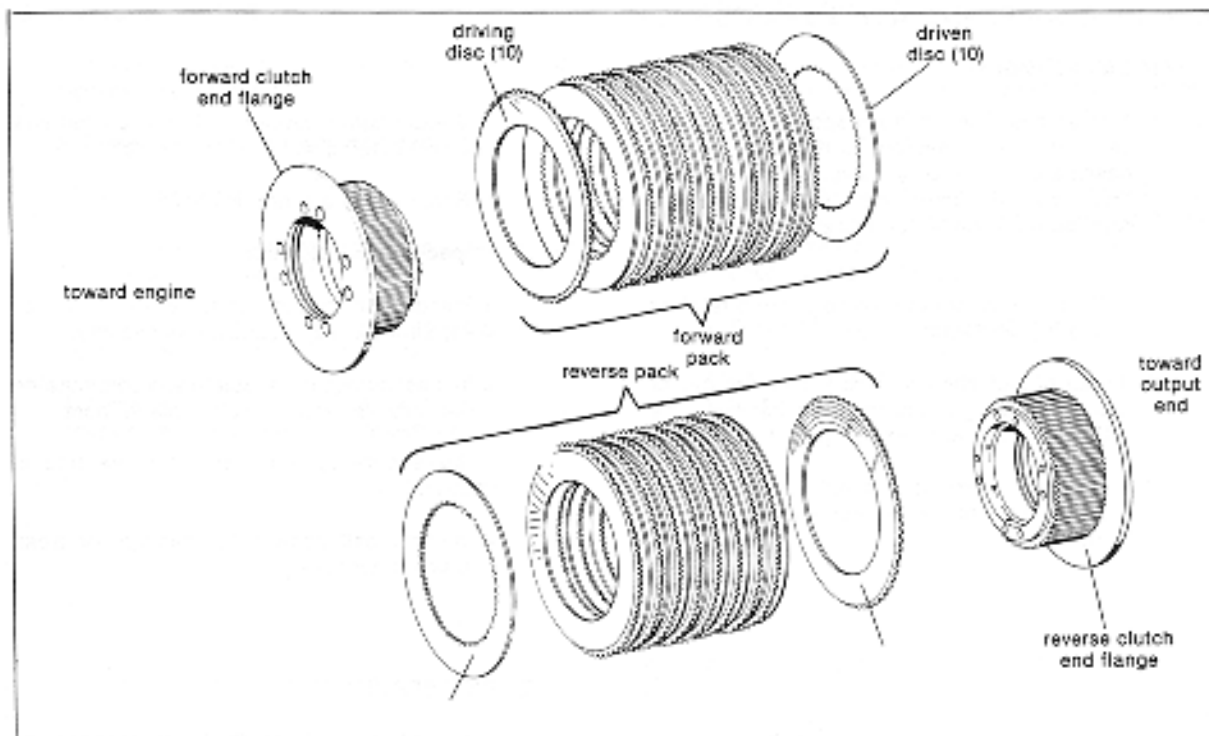

Fig. 30. HP 500 Clutch Disc Configuration (1-00100-2420 Clutch only)

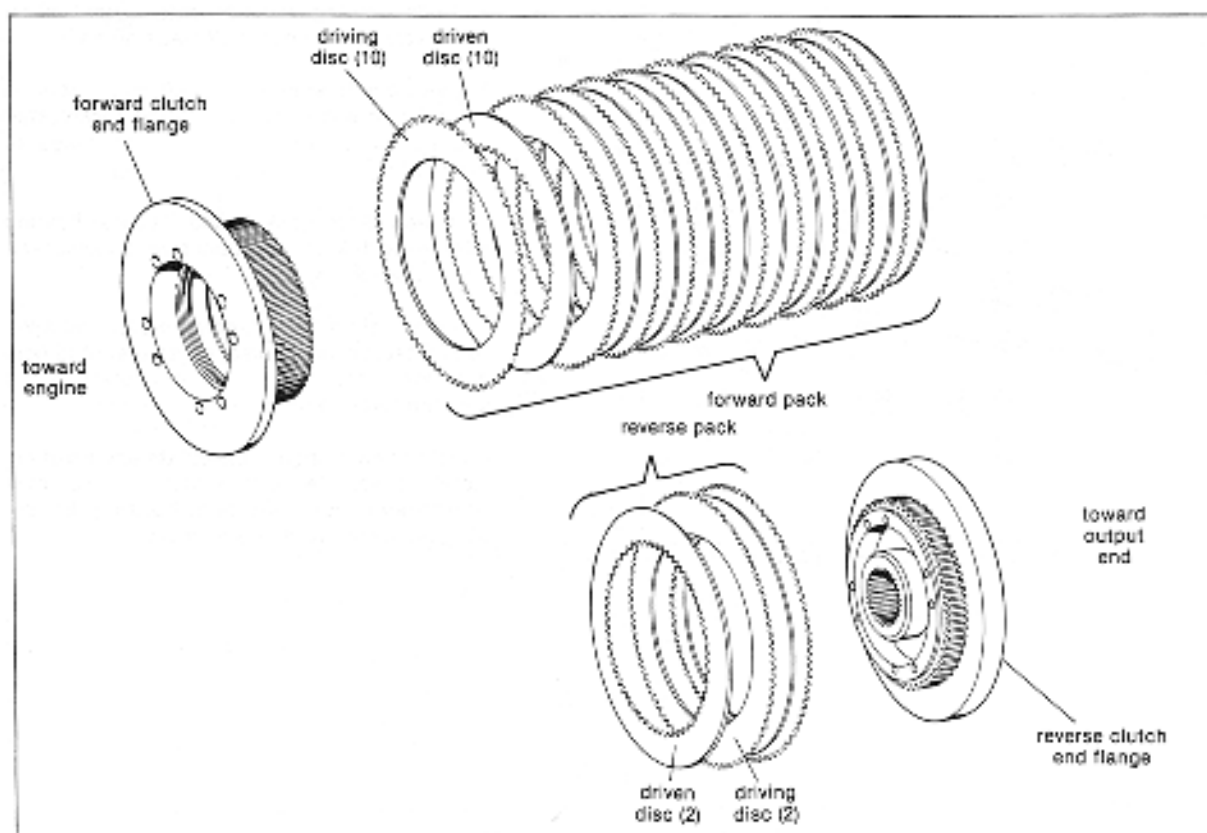

Fig. 31. HP 500 PTO W/Brake Clutch Disc Configuration (1-00100-4300 only)

7.4 OUT PUT SHAFT AND RELATED PARTS

A) DISSASSEMBLY

1. Remove hex head capscrews holding selector valve base plate with selector valve. Lift commutator tubes out of commutator and remove anti-rotation stud. Slide commutator off of output shaft.
2. Remove capscrews holding bearing retainer to bearing container.
3. Tap output shaft with soft hammer out of housing (bearing and bearing retainer will come with shaft.) Discard retainer gasket.
4. Remove bearing locknut with spanner wrench and remove lock washer. See fig. 32 below.

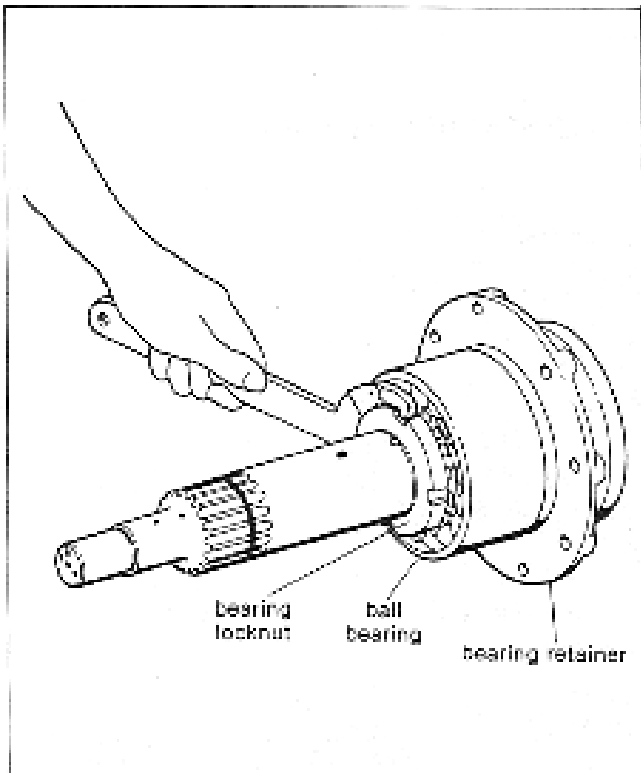

Fig. 32. Removing Bearing Locknut from Shaft.

5. Press bearing retainer off of shaft (Oil seal and ball bearing will come with shaft).
6. Remove and discard oil seal

B) INSPECTION AND CLEANING

1. Inspect commutator for damage or wear (See wear limits p.22) Replace if necessary.
2. Inspect O-rings in base plate and commutator. If they are no longer pliable replace them
3. Make sure commutator tubes are free of obstruction.
4. Inspect ball bearing for damage or wear. Replace if necessary

C) REASSEMBLY

1. Press in new oil seal flush with rear surface of bearing retainer.
2. Slide bearing retainer onto output shaft being very careful not to damage oil seal.
3. Press ball bearing onto shaft so it seats on shoulder of shaft. Install bearing lockwasher and tighten bearing locknut. Bend tangs of lockwasher.
4. Install new gasket and secure bearing retainer to bearing container with capscrews and lockwashers.
5. Install new o-rings in commutator and slide commutator in place on shaft so that stud hole is on starboard side. Install commutator tubes and anti-rotation stud.
6. Install new o-ring in baseplate and carefully install baseplate and selector valve over commutator tubes and onto housing. Secure with capscrews and lockwashers.

7.5 HOUSING PARTS

1. Clean oil breather and suction screen and replace filter element.
2. Flush clean and inspect main housing
 - a. Clean sump
 - b. Check front bell end for nicks and burrs. Use a flat file for deburring
3. Inspect reverse clutch drum for grooves or excess wear. Replace if necessary.
4. Inspect surfaces of output flange and mating coupling and file smooth if necessary.

7.6 ADAPTER GROUP

1. Clean and inspect stub shaft (mounted on engine flywheel) and forward clutch driving drum. Inspect spline on stub shaft for chips or wear. Replace as necessary.
2. Remove oil dam and inspect labyrinth oil seal on inside diameter. Repair or replace as necessary (wear or damage to seal indicates misalignment- check further!) (See fig. 33).
3. While oil dam is removed inspect flywheel adapter and drive flange for distortion or rough mounting surfaces. Repair or replace as necessary.

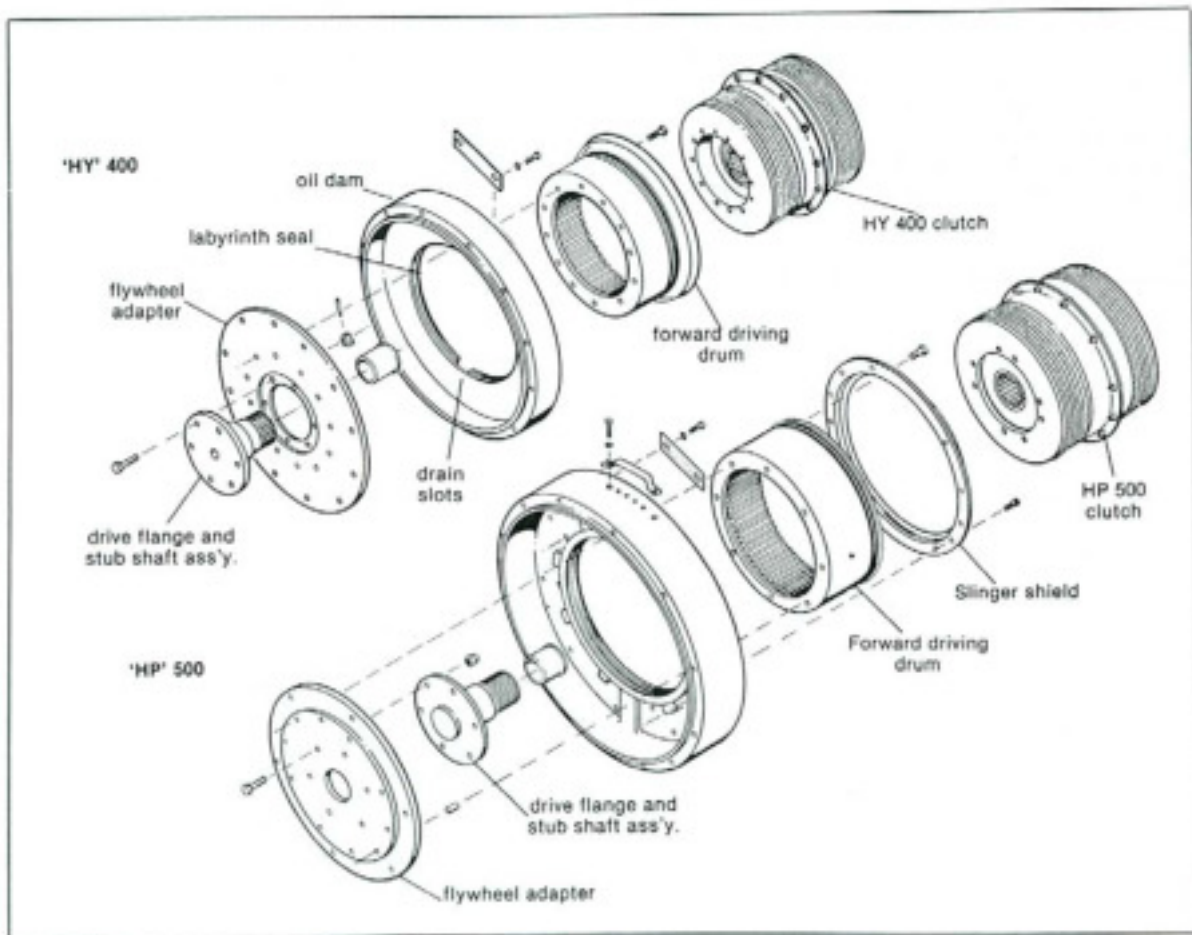

Fig. 33. Adapter Group and Clutch

